

University of Puerto Rico Rio Piedras Campus
Dean of graduate studies

The Sound Pavilion

Defense
June 14, 2021

Student
Reinaldo E. Hernández Aracena
801-10-3123

Director
Arq. Manuel Bermúdez

Collaborators
Arq. Andrés Mignucci
Ing. Jorge Rocafort

Index

1. Dwelling and our senses	1
2. Theoretical Framework	6
3. Aural Spatialities	9
4. Materiality and application	16
5. The Sound Pavilion	18
6. The Narrative	22
7. Programa	28
8. Bibliography	43
9. Design	44

1. Dwelling and our senses

The act of dwelling is a sensorial experience that relies on a continuous stream of information from our eyes, ears, nose, mouth, and skin to develop an emotional and intellectual understanding of our environment. Architects, for the most part, have focused on the sense of sight leaving all other sensorial experience as secondary importance limiting our profession's ability to create rich sensorial experiences. By exploring one of the fundamental aspects of dwelling, in this case sound, I will study how the manipulation of sound in architecture can allow us to further understand our environment. By utilizing Aural Architectural theory as developed by Barry Blesser and Linda-Ruth Salter I will be able to study the interactions between our auditory senses in relation to natural and built environments, while also concerning myself with the experience of sound that have been altered by the physical properties of a designed space. In this thesis I propose the creation of an Aural Pavilion in el Yunque Rain Forest in Rio Grande, Puerto Rico as a way of exploring these auditory and aural experiences with relation to our natural environment and the relations these sensorial experiences have with our ability to dwell.

In the essay *The Phenomenon of Place*, Norwegian Architect Christian Norberg-Schulz coined the term *everyday life-world* as a way of describing the world's physical & metaphysical phenomena. For Schulz space had a taxonomy that could be broken down into individual elements: People, vegetation, dirt, mountains, boulders, wood, water, cities, towns, streets, sidewalks, sounds, heat, etc. The combination of this physical and metaphysical phenomena being the content of our experiences. For Schulz "Everything else, such as atoms and molecules, numbers and all kinds of "data", are abstractions or tools which are constructed to serve other purposes than those of everyday life."¹

These experience-based phenomena are usually interwoven in complex ways. For example, beaches are constituted by water, sand, vegetation, light, shadow, the sound of the breeze, etc. It can be said that some phenomena or the combination of them form "environments". A physical term for environment is a *place*, and a place can be understood as an integral part of existence, since it is impossible to imagine anything happening without a place. But the term place means more than just an abstract location as Schulz best explains it as:

¹ Norberg-Schulz, Christian. "Genius Loci: Towards a Phenomenon of Architecture." Academy Editions (1980): 6.

“a totality made of concrete things having material substance, shape, texture, and colour. Together these things determine an “environmental character”, which is the essence of place. In general, a place is a given as such a character of “atmosphere”. A place is there for a qualitative “total” phenomenon, which we cannot reduce to any of its properties, such as spatial relationships, without losing its concrete nature of sight.”²

Therefore, the environments of buildings and cities consist of a multitude of places. Contemporary practices in the field of Urbanism and Architecture already take this notion into consideration as theoretical frameworks but so far, the problem of our feelings and by extension our senses have been treated as a secondary condition of the place except for the sense of sight.

Architecture, for the most part, has focused on an ocular-centrist design philosophy that has placed sight above all other senses, neglecting the impact certain materials, wall placements, ceiling heights and spatial distributions may have on the experience of a place or a designed space. This ocular-centrism is blatant even in our language, our daily vernacular is filled with expressions that center around the idea of seeing as analogues to understanding. As Kenneth Frampton points out in his book *Towards Critical Regionalism* “The etymological root of perspective comes from the idea of a rationalized sight or clear seeing, and as such, it presupposes a conscious suppression of the senses of smell, hearing and taste and a consequent distancing from a more direct experience of the environment”³ (much like Heidegger’s concept of “loss of nearness”⁴). It could also be argued that the profession’s obsession with how architecture looks has led to architectural designs that shock the eyes but fail to impact our other senses in the same magnitude.

Heidegger’s definition of dwelling, which differs from the commonplace definition of a residence; rather presupposes a relation between humanity and the world it inhabits in a “profound sense”. The notion is better understood in Heidegger’s *Building Dwelling Thinking*, in which he remarks that:

“[...] human being consists in dwelling and, indeed, dwelling in the sense of the stay of mortals on the earth.

² Norberg-Schulz, Christian. “Genius Loci: Towards a Phenomenon of Architecture.” Academy Editions (1980): 6-8.

³ Frampton, Kenneth. “Towards a Critical Regionalism: Six Points for an Architecture of Resistance.” (1981) 5.

⁴ A loss of intimacy between humans and their environment.

But 'on the earth' already means 'under the sky.' Both of these also mean 'remaining before the divinities' and include a 'belonging to men's being with one another.' By a primal oneness the four—earth and sky, divinities and mortals—belong together in one.”⁵

What Heidegger means in this excerpt is that human beings “dwell” where they feel connected to their environment, between the earth and sky. Another important aspect to note is the social dimension of dwelling, since as Heidegger points out “belong to men’s being with one another”; or our social cohesion in any given place. Although Heidegger mentions the concept of divinity and mortals as well (while it is an integral part of dwelling because of the implications of culture), we will not fully delve into those concepts but rather simplify them into our cultural interpretation of our environment. All these concepts when synced with one another lead us to what Heidegger calls ‘the mystery’.

It is also important to note that when Heidegger intentionally paints a poetic landscape rather than a scientific description of the earth and by extension the act of dwelling:

“Earth is the serving bearer, blossoming and fruiting, spreading out in rock and water, rising up into plant and animal... The sky is the vaulting path of the sun, the course of the changing moon, the wandering glitter of the stars, the year's seasons and their changes, the light and dusk of day, the gloom and glow of night, the clemency and inclemency of the weather, the drifting clouds and blue depth of the ether.”⁶

Places cannot be described only by analytic or scientific concepts, since what is being described in these cases is the everyday life-world (or the experience of the world through our own senses), which is often given great importance by city planners and architects. An alternative is to turn to Phenomenology, which is the study of structures of consciousness as experienced from a first-person perspective. The central structure of an experience is its intentionality, its being directed towards something, as it is an experience of an object or environment. And it is through this philosophical tool that Heidegger conceives the human experience as poetic by nature, it is because of this that when he defines dwelling, he determines that we inhabit the “poetic”. But the concept of dwelling as poetry also implies a connection to the environment, a connection which leads to more information and a deeper understanding of what he calls the “the mystery”.

⁵ Heidegger, Martin. “Building Dwelling, Thinking.” London: Routledge, (1993): 351.

⁶ Wheeler, Michael, “Stanford Encyclopedia of Philosophy: Martin Heidegger”, seen on 1/3/2020, <http://plato.stanford.edu/entries/heidegger/>.

This “mystery”, Heidegger claims, opens up a meaningful and particular way to any individual as a result of the specific heritage (the cultural aspect mentioned before), in which he or she has been encultured, assuring that there are a vast number of alternative field of intelligibility in the world that would be available to each of us, if only we could gain access to them by becoming simultaneously embedded in different heritages. This is only possible through our ability to dwell.

In this way, when we dwell, we dwell in the poetic, and by dwelling in the poetic we are connected to the “mystery” which in turn gives us the ability to gather information about the world and our environment; allowing us to better interpret what is around us from a Phenomenological approach. But in order to dwell we must be connected to our physical environment, which means a full sensorial connection; and since architecture as a discipline has in its most part focused on the ocular centric experience, it has left us scarce of opportunities to sensitize ourselves to our other senses. So it is only in the pursuit of a more direct experience, by engaging in an augmented scenography (or the engagement of all our senses) that we are able to connect to this “mystery” which allows us to better interpret our environment and by extension the world. And although we cannot attend a complete sensorial experience in this thesis because of the limitation of time and resources, we will instead focus on an augmented scenography involving sound in much the same way Kenneth Frampton concentrated on the touch with his study of the Tectonic. This is not to say that the other senses will not be attended to but rather that the focus will be on sound and our relation to it. Using Heidegger’s definition of dwelling as a theoretical base and by exploring in both theory and design the Aural Experience of architecture we will contribute to the further understanding of an architecture of full sensorial stimulation (the direct experience allowing us to dwell) through one of its defining elements, sound.

Heidegger remarked that “Poetry does not fly above and surmount the earth it orders to escape it and hover over it. Poetry is what first brings man onto the earth, making him belong to it, and thus brings him into dwelling.”⁷ Only poetry makes human existence meaningful, taking as a maxim that meaning is a fundamental human need. And as Schulz observes “Architecture belongs to poetry, and its purpose is to help man to dwell.”⁸

⁷ Heidegger, Martin. “Poetry, Language, Thought”, New York (1971): 2.

⁸ Norberg-Schulz, Christian. “Genius Loci: Towards a Phenomenon of Architecture.” Academy Editions (1980): 6-8.

But architecture is only possible when environments are made comprehensible; In other words, it can be said that the task of architecture is to make understandable a certain place and make its environment legible to the common person, in this way protecting our anthropocentric environment and helping us become part of it, since humanity is an integral part of the environment. By focusing on the phenomenological experience of architecture, I plan on developing an Aural Pavilion in hopes of creating a controlled spatial experience with the purpose of sensitizing people to the aural experience in much the same way architects have, for much of the discipline's history, sensitized people to the ocular importance of our environment. By creating certain extreme aural conditions, I hope to further educate the spectator of the aural environment in their everyday lives which should, in theory, bring us closer to a more complete sensorial experience and allow us to dwell.

2. Theoretical Framework

To create an augmented scenography of sound it is necessary to establish a method of design focused on the senses. Therefore, rather than focusing on acoustic I have decided to utilize Aural Architecture since it is not the physics of sound which interest us but the phenomenological experience of the built environment where people dwell. What exactly is Aural Architecture? In Barry Blesser and Linda-Ruth Salter's publication *Aural Architecture: The Missing Link*, they define Aural Architecture as the "human experience of sound-in-space; [...] aural architecture of a space modifies the experience of sound sources as well as provides a means for experiencing passive objects and geometries directly. To discuss the dual experience of aural architecture without reverting to the narrow scientific concept of Physical Acoustics, we use the word Spatiality for describing how people experience space by listening."⁹

The development of Aural Architecture also implies an understanding of how Spatial Acoustic can change the entire experience of an environment depending on its context. The same way it is difficult to determine "what is art?" outside of a museum, it is also difficult to determine a violin concerto's genius in a subway station rather than a concert hall¹⁰. This difficulty, however, cannot be explained by a change in acoustics, while the study of Physical Acoustics and Aural Architecture are related, they have profoundly different emphases. Physical Acoustics uses scientific language to describe the way in which Spatial Acoustics changes attributes of sound waves, while Aural Architecture considers the experiences and behaviors of the people experiencing a place (or the phenomenological experience). While Physical Acoustics emphasizes on the measuring and modeling of certain sound waves, the other explores a complex interactive phenomenon depending on cultural and personal biases. Because it is measurable more emphasis is given to the understanding of Physical Acoustics of enclosed spaces in the 20th century. It is only recently that academic investigators have begun to focus on Aural Architecture, developing a language based on borrowed terminology for visual architecture (illumination, arena and boundary) while also developing in close relation to acoustic studies in order to understand the soundscape's effect on ourselves.

⁹ Blesser, Barry and Salter, Linda-Ruth. "Aural Architecture: The Missing Link" *The Journal of American Acoustics* (2008): 6-9.

¹⁰ This was the case of world-famous violinist Joshua Bell who in 2007 played on DC's metro station with a 3.5-million-dollar Violin. He was surprisingly not recognized by anyone being ignored almost entirely by the people none the wiser of the great violinists' presence;.

In order to create a common language for discussing Aural Architecture we will use the recently developed concepts Aural Architects call Spatialities, as a way to describe the phenomenological auditory spatial experience. Spatialities are composed of various elements: navigational, social, musical, aesthetic, and symbolic Spatialities. Consider them to be heuristic tools in progress, open to expansion and adjustment. Because *Spatialities* exist from the phenomenological experience of the listener, they present an image of place different from the usual static, three-dimensional conception of geometric space. Putting it in simple terms, these Spatialities can change our perspective of a place we are inhabiting through the framing of sounds (or what amounts to the same, their negation), integrating sounds which might seem far away into an experience or concentrating nearby sounds towards a singular point (or various points). While each type of spatiality possesses its own defining logic, all five can exist simultaneously overlapping and intersecting one another. Together they describe the natural multidimensional nature of experiencing an Aural Architecture.

Aural Architecture is often determined by its environment, and because of this soundmarks are often primary focuses. Soundmarks are a community of sounds which are unique or possess unique qualities which make it special to its people or community. Because of the Soundmarks' cultural and historic significance, it merits preservation and protection to conserve a culture's aural identity. By incorporating elements such as these in the process of design Aural Architecture uses its environment's pre-existing aural conditions to transmit information in a controlled and intentional manner.

As an example, a type of Navigational Spatiality, Spatial Spreading, described the transformation of a source of sound into an enveloping cloud that overwhelms the listener in a diffuse sound field, making orientation impossible. The visual analogue corresponds to a spherical room with surfaces of frosted glass illuminated from behind with a uniform light. From a biological and evolutionary perspective, our binaural ability to localize prey and predator probably had important survival value for our ancient ancestors. Conversely, the inability to localize can produce increased anxiety, wariness, and arousal. Today a fire truck siren in a city can produce anxiety because of the doppler effect while also leaving people anxious about moving out of the way as to not obstruct the passing of the truck.

Symbolic Spatialities also help us determine ourselves inside of a space, by considering the auditory Mass we can modify sound to appear louder than they should be. Auditory mass is the perceived size and dominance of the sound source which is unrelated to the actual sonic event. Rather, the early reflections within the first 100 msec, especially when

arriving from the side, make the sound source appear to be larger, louder, and more prominent.

3. Aural Spatialities

A fundamental aspect of Aural Spatialities are Aural Arenas. These Aural arenas are the basis for all aural experiences since it is the delimited spaces in where an Aural Experience is undergone by two or more people. These physical delimitations are established by various factors, the size of the arena (or in other words until what point we hear the sound come from). Arenas can be as big as basketball stadiums or as small as small droplets of water on a zinc roof.

Because Aural Architecture delimitates a space through boundaries it is also used for navigational purposes, these are called navigation spatialities. This term refers to the aural cues that allow us to move through a space without the necessity of sight. This is done by associating certain areas with distinct sounds, their volume and their fidelity (this is also known as echolocation¹¹). We use this echolocation daily, often receiving reverberated sound from concrete walls because of the low-frequency sound they emit from their surfaces. Often, we can **hear** where a bathroom is because our cultural bias favors the tiling of the entire space. The material's resonance informs us about the vastness of the space and what's occurring inside at a distance. We often do this in wells and caves shouting or throwing a rock into them to hear the reverberations that carry with them information about the area and volume of the well or cave.

Aural Spatialities are specific experiential Aural Arenas with their own boundaries that connect people to the environment or others through acoustic information. Similarly places are often determined by boundaries, the most obvious for most being visual but these boundaries are also multi-sensorial, they depend on walls, edges, roofs, people, landscapes, boulders, mountains, domain classification (public, private and their variants), and etc. all determining a right to access in one way or another. Hearing is associated with invisible boundaries that demark the region within which a listener can hear events. The edges of the Arenas are often known as Acoustic Horizons and are determined by the volume of the sound and by its fidelity.

Since the aim of this thesis is the creation of an Aural Pavilion it is important to develop delimitations for Aural Arenas, and how they can be used to further create and promote certain environments and experiences for the inhabitants of a place. This is to say the creation of certain "rooms" with their own aural aesthetics. Determining the shape and size of these Aural Arenas depends on various considerations, for example: intensity of

¹¹ A location of an object by reflected sound.

the sonic event, the acoustic of the container, the perceptual/cognitive abilities of the inhabitants, the masking qualities of ambient sound or reverberation, and local acoustics¹². It is because of this that Aural Arenas may have unusual shapes in order to promote certain experiences. Curved walls can focus sound, thereby extending an arena in one direction while shrinking it in another. Reflecting surfaces act as amplifiers in certain areas of space, while sound absorption shrinks Aural Arenas creating the possibility of multiple small arenas. But all these spaces are incomplete without the behavior of their inhabitants.



Figure 1 view from the Mameyes II road looking into the visually unending rainforest with the overlap of the sonic environment.

¹² If there are walls in the surrounding areas with certain heights, perforations, materiality, or lack of any physical object.

Blind individuals are said to have a refined art of “seeing” space through listening; the french philosopher Diderot first reported the phenomenon in 1749, and Studying how some individuals could distinguish square, circular, and triangular objects by listening. There are tours of El Yunque for the blind which move them around different areas so they can enjoy the sounds of the rainforest. Those who are not visually challenged are unlikely to depend on hearing to navigate through space unless thrown into total darkness. Regardless, Navigating Spatiality is another way of relating to a place; when we walk through a location listening to loud music on headphones, our senses of confidence diminish because of our loss of connection to the aural cues that we subconsciously use to navigate. This is because there is no place without its own unique sound, all spaces also create enough sonic information that allow us to navigate through them.

Aural Arenas don’t necessarily have to be tied to a physical location. Since Aural Architectural is composed of experiential places, an arena can take the form of an earphone, a listener embedded in the musical space of a recording rather than in the physical place. Experiential Aural Arenas and Physical Arenas can also overlap. Consider the case of an individual talking on a cellphone while cycling, physically he is moving through a place, while experientially he is sharing an Aural Arena with his partners. Technology has made it so that we can switch among Aural Arenas while never having to move physically. We can have a conversation with our neighbors while at the same time eavesdropping into other conversations nearby and register the sound of a doorbell heralding people into a home.

This is perhaps more palpable in a natural environment. If you were to enter a rainforest you would be greeted by an assortment of Aural Arenas occurring simultaneously. Not only would you hear the sound of birds communicating, but also those of bugs. You would also experience the wind through waves of gust and the rustling of leaves. Additionally, unbeknownst to those experimenting these sensations other animals could be lurking nearby, breaking dry, brittle branches. But in urban environments such as Bayamon’s urban center most of the sound arenas occur from the flourishing of human gatherings. These arenas come from the various businesses and food venues that seek to attract customers through an alluring acoustic environment, usually inviting musicians or singers as entertainment or, in the case of places like “El Nido” they create cultural gatherings based on Puerto Rican culture with reggaeton, poetry, bomba, salsa and plena celebrating their position next to the train both visually and aurally as it has become an iconic symbol of the business’s aesthetics. (Figure 2)



Figure 2 A picture in where many Aural Arenas can be viewed. The singer, the audience, the train (structure to the right) and the totality of the thing itself.

Aural arenas are governed by the cultural rules of their environment, or what Social Anthropologist Edward Hall calls proxemics. If we are thrust into an Aural Arena that isn't similar or matches our cultural heritage, we experience a loss of comfort. Hence eavesdropping on strangers is intrusive, whispering is highly intimate and shouting at someone standing next to you is punitive. To be socially useful, Aural Arenas and their properties must match the cultural norms governing the social spheres of their environment. A place designed to have a good Social Spatiality will have the acoustic design that supports the appropriate size and shape of its Aural Arena. It also induces its inhabitants to create sonic events at the appropriate intensity to use the space.

The nuances of what we consider a pleasant aural environment in each culture can change how these arenas interact; for example, Puerto Rican culture is often considered loud when compared to European or Asian cultures. Thus, an Aural Arena in Puerto Rico

would probably make a foreign spectator uncomfortable in an aural sense, affecting their connection to a place's cultural and physical presence, and by extension further separating the person from being able to dwell in the site.

Similarly, when we talk about Symbolic Spatiality, we imply a connection or continuity between events, places and experiences, it is the name given to the places or events that become closely associated with spatial acoustics. Although visual symbolism is the most popular form of this, the process of symbolic linkage also takes place with the other senses. We usually call these visual Symbols Icons and by symmetry, aural symbols are called earcons, which may be either abnormal environmental sonic events or spatial acoustics. Any Soundmark coupled with a certain event can, with repeated exposure or emotional connection, become associated with the meaning of a place. Even though earcons are seldom the result of conscious design intention, symbolism results from the marking of a person with a certain sound.

An example of this can be experienced in the stone and wooden materiality of cathedrals that have become synonymous with the great reverberations and acoustic design. After hundreds of ceremonies, the attributes of both visual and aural architecture come to represent God's home. Similarly, the damp acoustics and impressive visual image of mist coming down a mountain, the blueberry like glow of a forest at night or the sound of unseen animals become symbols of nature. The sound of gust in a penthouse can also become a symbol of wealth, the diffused echoes of a vast office entry the symbol of power, and the well-designed podium can convey an energy of power or a symbol of dominance.

The development of earcons and by extensions the adaptation of Soundmarks can contribute to the creation of a unique sense of place. Architectural globalization has often been criticized for producing uniform, sterile spaces, devoid of meaning and experiences, where it is easy to become disoriented and lost. Differentiation among spaces can be developed through creating symbolic, meaningful earcons that produce unique and memorable aural experiences. Although like the concept of Soundmarks, earcons are distinct in the sense that they are produced through Aural Architectural design rather than a priori to the architect's intervention. It is because of this that Aural Arenas are incomplete without its Aesthetic Spatiality.

Aesthetic Spatialities describes the rich variety of local acoustics that provide varying auditory texture. Reverberation timbre depends on the type of surfaces in a space. One could imagine a wall composed of alternating resonant cavities, absorption panels, and reflective surfaces that change the experience of sound as one moves alongside it.

A place can have multiple Aesthetic Spatialities, consider the sinuous ceiling of the Barajas-Madrid Alfonso Suárez Airport in Spain. Because of the airport's distinct curved ceiling, moving from a flat ceiling surface to a curved wooden ceiling surface can create a dissonance in the acoustic experience. While the flat ceilings have been designed to control the acoustics of the space in a uniform manner, the curved ceiling because of its sinuous nature, creates an echo effect reverberating sound from one area of the airport to another (Figure 3). Plush upholstery and deep pile carpets create an aural sense of warmth that arise because they absorb almost all the high frequency sound energy. Conversely, marble floors and glass walls create an aural sense of coldness because they reflect and magnify the high-frequency sounds.



Figure 3 An example of aural aesthetics and the profound change of materiality from a flat ceiling height in the peripheral edges of the picture and the great wooden roof in the middle. One can almost hear the difference between sounds by looking at the picture.

To conclude this chapter, it is important to note that the elements used to design a public and private Aural Architectural experience are the same although their distribution, placement and intentionality are distinct. I have not made emphasis or been divisive on the elements as strictly private or public because they are applicable in both cases as primordial essential elements of design. During the design phase, both the public and private space will be composed of these Spatialities, to develop a unique aural

experience but in different ways. Public realms develop Aural Arenas that will, using the Spatialities, include its surroundings into the design, while the private realms will both accept and negate their surroundings, molding them into the experiences convenience, since the primary focus of the Thesis is to understand dwelling as an augmented scenography. For example, while a public Aural Architectural design might, because of its specific circumstance, focus on Symbolic Spatiality as a way of making the place memorable, a private Aural Architectural design might consider placing more importance on Aesthetic Spatiality in order to develop a dialogue with the exterior in order for a more fulfilling and direct experience.

4. Materiality and application

Since the aim of this thesis is the exploration of our senses and their relation to our ability to dwell with an emphasis on sound, it is important to tie central concepts used in the theoretical chapters of the thesis with the physical counterparts that make them possible. The purpose of this is not only to produce tools and knowledge in order to execute the project but also to give future generations the conceptual and applicable knowledge that would allow them to recreate Aural Designs.

Concepts to be explored:

1. Aural Arena: Aural Arenas are the acoustic delimitations of a place between two or more people, it is important to note that Aural Arenas don't have to be connected through a physical location. The design of an Arena can take many forms, from a space in which you share a certain Soundscape with a person, to a room dedicated to communication with another space at a distance. Aural Arenas can be amplified by electronic & analogous means which means the extension of an Aural Arena may be limited to either amenities such as speakers, internet, phones, walls, ceilings etc.
2. Diffused Sound field room: Spatial spreading describes a room with the properties of a diffuse sound field. In other words, the room is a sound pressure field where there is no privileged direction of the energy: sound pressure is the same everywhere in the room and the sound in the room does not appear to have a singular source. A way to create this type of room is to have a large room with no absorbent materials on walls, ceilings, or floors, making them completely reverberant. The effect is magnified in asymmetric rooms.
3. Aural Spatiality & Aesthetic Spatiality: Rooms with Aural Spatiality & Aesthetic Spatiality create relations between the inhabitants of a place and the sonic environment created by the placement of objects, walls, ceilings, and specific materiality.

4. Symbolic Spatiality: A place with an aural experience that is tied to its typology or location. Symbolic Spatiality relies on the monumentality of the design. It creates nodes of interaction between a given place and our sensorial experience.

5. Anechoic chamber: rooms designed to absorb reflections of sound. They are often isolated from external sound waves entering from their surroundings. In other words, the person experiencing this space hears only direct sound (an effect closely resembling being inside an infinitely large room).

In such a room human being would perceive their surroundings as being devoid of sound (an effect which can leave people disorientated). The way to achieve this effect is by clocking the walls with a series of “wedges W” and “Height H” acoustic panels around the entire walls, ceiling and sometimes even the floor (depending on the desired effect). (Figure4)



Figure 4 An Anechoic chamber inside the University of Bristol's faculty of engineering

5. The Aural Pavilion

A Museum is an institution that cares and conserves artifacts and objects of artists, culture and of scientific importance. These items are usually presented through exhibitions for public viewing that can be both permanent and temporary. The purpose of contemporary museums is usually to collect, preserve, interpret, and display the objects for the education of the public.

Nina Levent and Alvaro Pascual-Leone's book *The Multisensory Museum's* approaches the role of sound in the museum from a history point of view claiming that we have begun to wise up to the acoustic practices of the 1960s art scene as well as the medium specific practices of the seventies and eighties. Curators now have begun to expand their critical vocabulary with acoustic terminology to understand the auditory complexity of our cultural history. This has in Alvaro Pascual-Leone's and Nina Levent's words initiated a "reassessment, a reevaluation of the growth of multivalent potential of sound to work both through and against its establishment as a medium, and acknowledgement as a phenomenon."¹³ In other words, it is only now that we are beginning to understand the importance of the aural experience in curated environments and how it is that these experiences can be used in order to further develop cultural historic narratives as a way of sensitizing the spectators to a certain idea.

The purpose of a museum can also depend on the visitor's predisposition. Museums can be educational for the average citizen as well as a place for entertainment and an enlightening way to spend the day; this is because above all Museums are storehouses of knowledge. In much the same way a Pavilion of Aural experiences would be a place for sensorial knowledge and enrichment. Departing from the traditional concept of a Sound Museum as is the case of the Museum of Sound in Saint Petersburg or the virtual museum of Endangered Sounds, which both house interesting and peculiar instruments and object which produce sounds, the Aural Pavilion would seek to create different Aural experiences for its spectators in order to sensitize them to their surroundings.

Following these maxims, an Aural Pavilion should encourage discovery and learning. It should be able to teleport the person inhabiting the place to another world where they would fully envelop the concept of dweller in the desired aesthetic experience. This, I argue, is evident in *The Jewish Museum in Berlin* by Daniel Libeskind which presents a cohesive story through aesthetic experiences developed through architectural design

¹³ Pascual-Leone, Alvaro & Levent, Nina. "The Multisensory Museum: Cross-Disciplinary Perspectives on Touch, Sound, Smell, Memory, and Space." Rowman & Littlefield, (2014): 117-118.

rather than cultural objects (although there are, they are not the main attraction of the museum) of the history of the Jewish people through the intentional design of drastically distinct rooms and passageways with their own materiality and aural experience which tell their own story. (Figure 5)

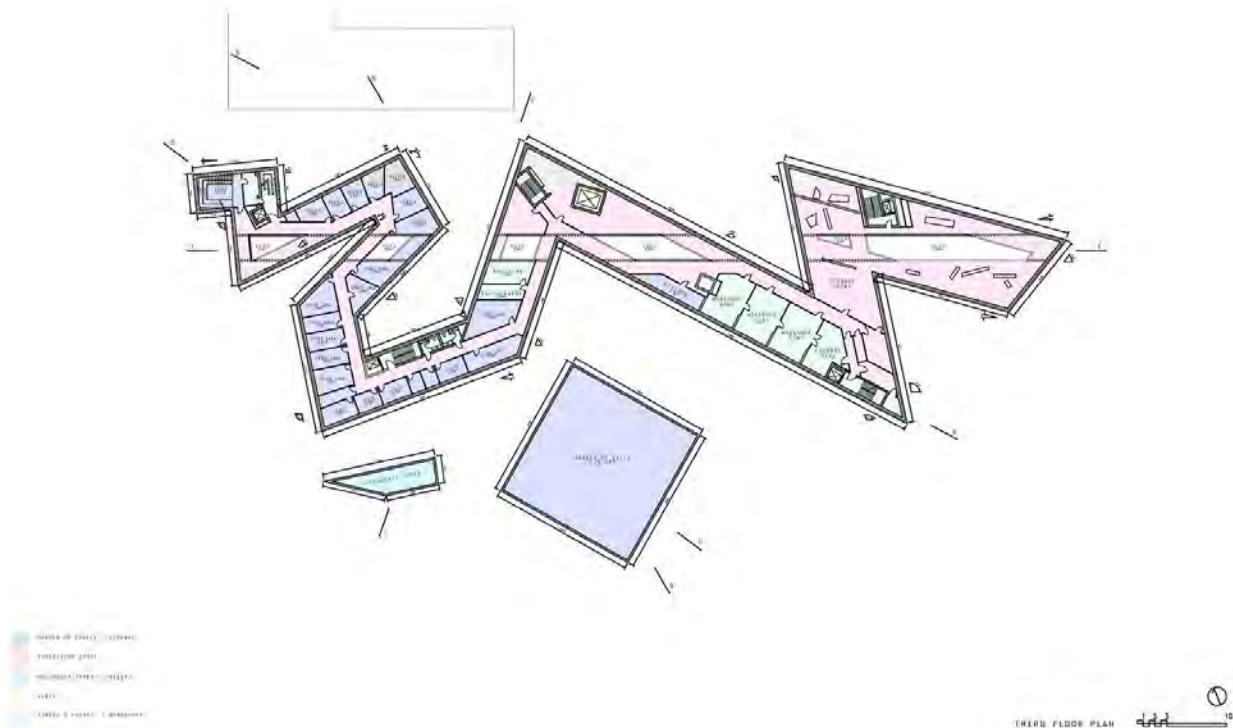

Figure 5 As can be seen from the floor plan, the museum's "erratic" bends create a sense of separation which it uses to its favor when creating certain aesthetics in each exhibition space. Rather than having many small rooms It is a complete narrative separated by bends in the path.

The Jewish Museum as can be seen above is separated mostly through its sharp turns, not only blinding the visitor from the next room but barring them from preparing their senses for what comes next. The act of separating the visitor sensorially from the other rooms builds up climax for what “comes next”. For example, a passageway may begin as an information room about the tragedy of the holocaust, notifying the reader about the experience intellectually, but then exploring the information sensorially as can be seen in the image below.



Figure 6. Steel plates on the floor have clear abstract faces on them as an allusion to the Jewish people, the metallic sound they make can be heard far beyond the narrow hallway. Taken from <https://www.inexhibit.com/case-studies/daniel-libeskind-jewish-museum-part2/>.

The floor is littered with metal plates with faces on them, the walls almost a hundred feet tall. The Aural Arena is characterized by the reach of the sound of the reverberation of the steel plates reverberating on the narrow concrete hallways. Libeskind composes a statement with regards to those lost in the tragedy through aural means with the intention of the sensibilization of the senses of the spectators in hopes of initiating them to dwell in this place. The design of the museum promotes exploration by giving the dweller no other choice. Once he is intellectually aware of the event, he is forced to walk through a

permanent installation which sensorially overpowers the individual as he makes his way through the long corridor.

In essence this is what the Aural Pavilion hopes to accomplish. The Aural Pavilion is a tool to help others become aware of their aural and acoustic environment. By creating different scenarios in which their acoustic and aural senses are aroused allowing the spectator to experience how these different scenarios inside of the Aural Pavilion in juxtaposition to the outside world. In other words, since dwelling depends on a connection between the senses and our intellectual understanding then the sound Pavilion's objective is to further develop our sense of hearing with regards to our environment as a way tool to further sensitize the spectator to their aural everyday environments.

6. The narrative

Constructing the experience of a building is often likened to a writer constructing a narrative. Writers often look to create emotional connections with their readers through the readers ability to understand and imagine objects through written cues. In much the same way architects design spaces to create a certain phenomenological experience. This narrative, in contrast to literature, if physically constructed into the world results in a more direct experience although similar depending on abstract suggestions to create a connection between the place and the spectator.

The idea of the Literary narrative can best be summed up using the poem “A Winter Evening” by Georg Trakl, also used by Heidegger to express the power of poetry as a vehicle for understanding the world:

A Winter Evening

Window with falling snow is arrayed,

long tolls, the versper bell,

The house is provided well,

The table is for many laid.

Wandering ones, more than a few,

Come to the door on darksome courses,

Golden blooms the tree of graces

Drawing up the earth's cool dew.

Wanderer quietly steps within;

Pain has turned the threshold to stone.

There lie, in limpid brightness shown,

Upon the table bread and wine.

Trakl uses worldly imagery to connect to the reader. It is because we all know what “snow”, “wine”, “bell”, “table”, and the “Golden blooms” of a tree are that we can imagine and place ourselves into this scenarios depicted in the poem, creating an emotional connection between us, the spectator, and the poetic object. The narrative consists, in this case, of a linear relationship between the subject and the object in which both become intertwined resulting in a personal experience.

An example of an architectural narrative can best be understood in the case of Peter Zumthor’s Thermal Vals. The project explores sight, touch, sound, smell, and its defining feature of our thermal sense. Located in the Graubunden Canton in Switzerland, the Thermal Vals was originally designed and built in a cold location, its primary intention was to connect to its surroundings by utilizing the existing thermal spring as the base for its design.

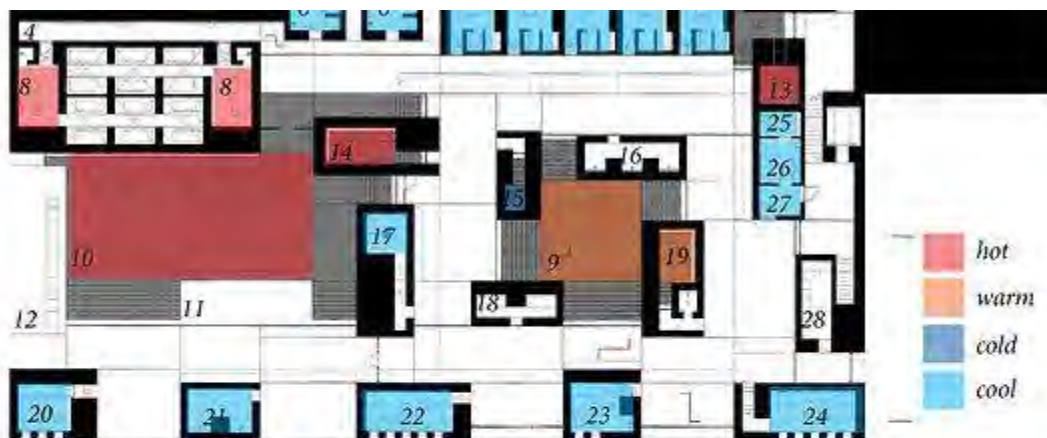

- | | | |
|--|-------------------------------|--------------------------|
| 1. Entrance/Exit | 13. Fountain grotto 36 deg. C | 25. Outdoor shower stone |
| 2. Utility | 14. Fire bath 42 deg. C | 26. Shared rest space 2 |
| 3. Makeup room | 15. Cold bath 12 deg. C | 27. Massage |
| 4. Hall way with water drinking fountains | 16. Shower stone | 28. Shared rest space 3 |
| 5. Changing rooms | 17. Drinking stone | |
| 6. Showers | 18. Sounding stone | |
| 7. Rest rooms | 19. Flower bath 30 deg. C | |
| 8. Hot room, 42 deg. C with 'Tummy stones' | 20. Shared rest space 1 | |

Figure 7. The spatial distribution of Zumthor’s Thermal Vals with heat distribution.

Taken from <https://zainaboyekan.wixsite.com/>.

It opened in 1996 predating the hotel complex built around its success. The focus of the narrative was to create the experience similar to a cave or quarry on the site of the hot spring as if the building itself naturally appeared on the side of a hilltop. The floor plan as seen above does little justice to explain the quality of the spaces although it gives us

an idea of its spatial distribution and by relation an abstract understanding of its narrative in the sense that we can see how rooms are connected to one another.

Another important narrative element in architecture is the materiality used to express a certain atmosphere, the Thermal Val itself is built upon layers of the local quarried valser quartzite slabs building upon the narrative of the building as an extension of the mountain itself. Alluding to the connection between the concepts of the written and narrative and built narrative (architecture), Peter Zumthor asked himself in the process of designing the Thermal Vals: “Mountain, stone, water – building in the stone, building with the stone, into the mountain, building out of the mountain, being inside the mountain – how can the implications and the sensuality of the association of these words be interpreted, architecturally?” The relation of the slabs is not only visual but also tactile and most importantly in the project thermal as it absorbs and releases a certain radiant of heat. This stone is transformed from the wild stone of the mountain to the tamed construction material used as a tool to express a certain atmosphere of a controlled space.



Figure 8. Picture of Green ceiling merging into the landscape. Taken from <https://www.thoughtco.com/peter-zumthor-architecture-portfolio-4065270>

The previously presented floor plans lack the function of fully expressing the atmosphere and experience of the Vals, the floor plans do not display the unique spatial design elements of each room. How the light, and the thickness and height of corridors and bath spots affect the experience of a person. Or how the connection of the building itself is fully dependent on the hot springs. This is to say that one would enter a hot spring in one area of the building only to have to leave the warmth of the water (into the cold of the mountains) to reach the next hot spring in the continuing room.

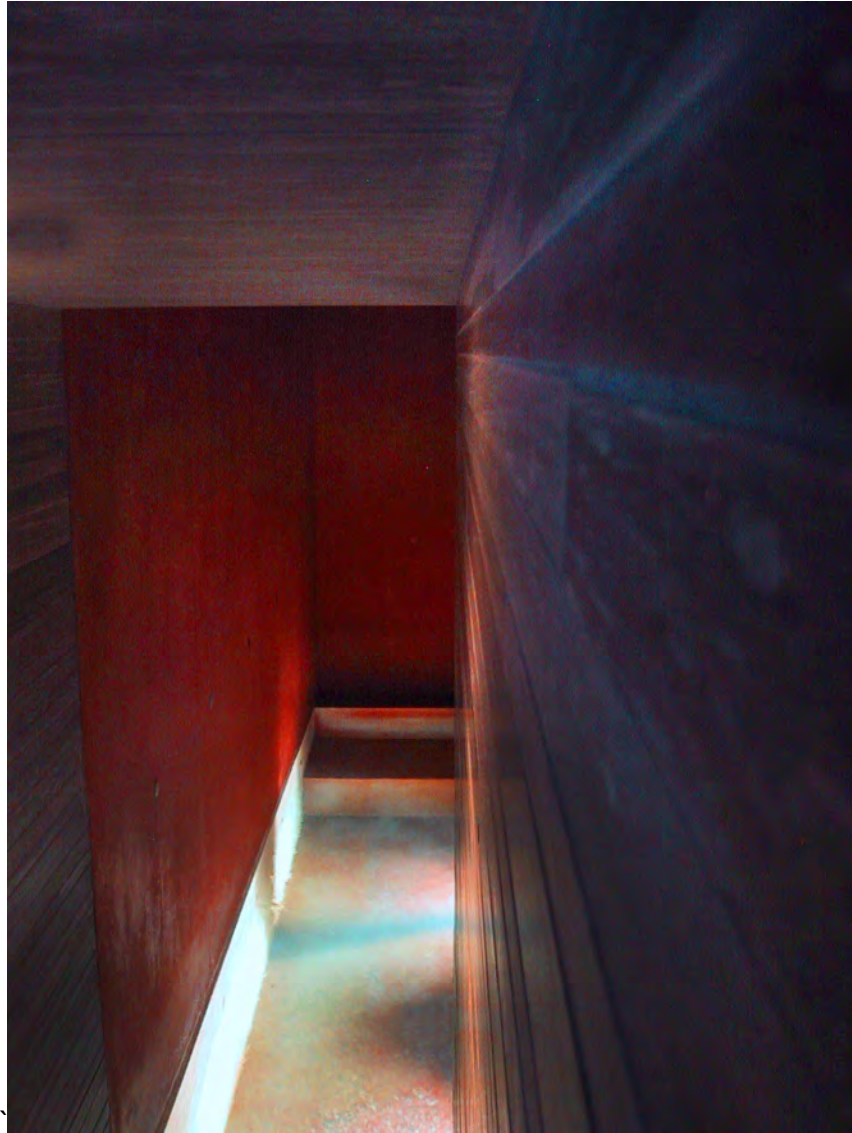

Figure 9. View from the thermal vals interior hallway's symbolic Spatiality of the cave.
Photo taken from <https://www.arch2o.com/the-therme-vals-peter-zumthor/>.

This separation of the experience is the foundation for the enjoyment of the space itself. The absence of the hot springs natural thermal experience between rooms promotes contemplation of the experience through both a physical and intellectual sense. The physical because of the absence of heat, plunged into the cold until one finds hearth in the warmth of the next hot spring and intellectual in the moment of finding the next room, and enjoying the experience as a whole rather than in segments.

John cage in his acclaimed piece titled 4'33" explored a similar experience through sound. It was in the absence of the spectator's expectation of sound in the piece that sound as an economic element was elevated. In the book *No Such Thing a Silence* by Kyle Gann, he expresses that "The audience expected sound from the musician and the performer expected silence from the recital audience. Often, both expectations were frustrated, as the musician made no audible sound and audience members cleared their throats, muttered, or heckled. The musician and the audience broke character in refusing to act out their conventional roles." In its absence (the absence of the desired phenomena) all that is left is for the active listener is to become a spectator in silence in where he is forced into a contemplative role. Although 4'33" uses silence to express an artistic motif it is important to note that it is not about listening to nothing, but rather about listening to everything.



Figure 10. John Cage sits in an Anechoic Chamber, all that is left to be heard is oneself. Taken from <https://rhythmanddrone.wordpress.com/2015/09/02/1951-john-cage-in-the-anechoic-chamber/>.

The Aural Pavilion's narrative can best be understood as a mixture of both Peter Zumthor's displacement of the body in and out of heat (or the exploration of a sense through its absence) and John Cage's exploration of sound through its apparent absence. The desired experience would be to plunge the spectator into an array of aural experiences ranging from dense reverberating rooms leading to an anechoic chamber. The multitude of rooms leading from one end of the spectrum to the other would explore how space can alter sound and create different experiences through it as was studied through Libeskind's Jewish Museum. Separating these rooms through areas of contemplation with direct contact with the natural environment.

7. Program

The first chapter dealt with the phenomenological concept of dwelling through the works of Heidegger and Norberg-Schulz, it explored the idea of an Aural Pavilion as an inquiry into the sensorial world focusing on sound without neglecting the other senses. The later chapters expanded upon this by exploring the physical properties of these aural spaces and the language used to interpret them defining aural spaces as Aural Arenas and the composition of these Aural Arenas as Spatiality's.

The overlapping Spatiality's were studied through the Barajas Airport in Spain as well as the acoustic properties of the materiality used. Additionally, environmental data such as Soundmark's and Earcons were also taken into consideration to fully exploit sound as an element of design.

Visualized as a Museum for the ear, the Aural Pavilion followed the familiar schematic distribution of what we could call a regular museum as can be seen in figure 11. The Pavilion's conception, however, did not revolve around the presentation of cultural objects as is usual, rather the narrative revolves around spaces which exploit the senses in different ways.

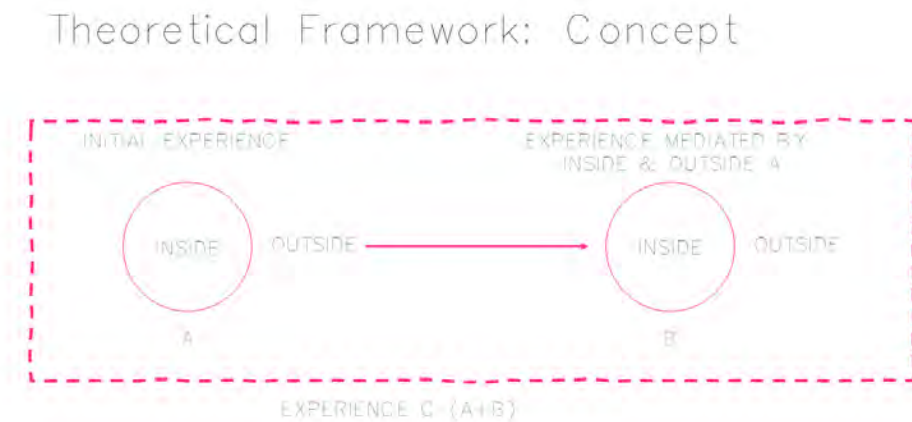

Figure 11. The Schematic distribution of a museum can be reduced to this diagram. There exists an overlapping institutional narrative (or experience c) that is mediated by an initial experience A and its absence and then experience B as mediated by experience A.

The act of reimagining the cultural objects displayed in museums as spatial experiences can also be seen in the Libeskind's Jewish Museum. The museum's Holocaust narrative is not only displayed in the information hotspots and cultural objects but also in the museum's design itself. Its floor plan being a result of a distorted Star of David while many installations, as were presented during the last chapter, also hold a significant symbolic representation of the Jewish people's suffering and eventual liberation.

Theoretical Framework: Thermal Vals

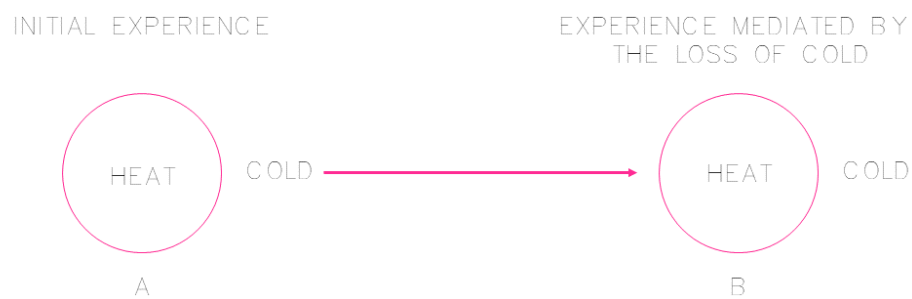

Figure 12. Abstraction of Zumthor's thermal Vals experience.

A similar exploration of the can be seen in Peter Zumthor's Thermal Baths. As the name would imply, Zumthor explores the thermal sense through heat and its absence without neglecting the other senses. This exploration of a constant eave and flow, as is seen in figure 12, a coming "in and out" of a sensorial experience can create multiple readings of an experience depending on the person's receptivity to the absence and then reintegration into sound. This eave and flow will be explored in the following 5 Spaces:

1. The lobby: Like all hubs this room is to familiarize the spectator with the experience. Here he will be able to study the concepts of the Aural Pavilion before he is thrust into the experience itself.

a. Materiality:

- Wall

Sound Absorption Coefficient/Scatter Coefficient							
Material	125Hz	250Hz	500Hz	1000Hz	2000Hz	4000Hz	NRC
Concrete, rough,	0.01/0.1 2	0.02/0.1 3	0.04/0.1 4	0.06/0.1 5	0.08/0.1 5	0.10/0.1 6	0.05
Gypsum Board, 5/8 in. thick (screwed to 1 x 3s. 16 in. oc with airspace filled with fibrous insulation).	0.55/NA	0.14/NA	0.08/NA	0.04/NA	0.12/NA	0.11/NA	0.10
Wood 1/4 in. paneling, with airspace behind.	0.42/0.2 0	0.21/0.2 4	0.10/0.2 6	0.08/0.3 2	0.06/0.3 6	0.06/0.4 0	0.10
Shredded-wood fiberboard. 2 in. thick on concrete	0.15/NA	0.26/NA	0.62/NA	0.94/NA	0.64/NA	0.92/NA	0.60
Steel	0.14/0.2 0	0.14/0.2 5	0.14/0.3 0	0.14/0.3 5	0.16/0.4 0	0.16/0.4 5	0.10

- Floor

Sound Absorption Coefficient							
Material	125H	250H	500H	1000H	2000H	4000H	NRC
	z	z	z	z	z	z	
Concrete	0.01	0.01	0.02	0.02	0.02	0.02	0.00
Wood	0.15	0.11	0.10	0.07	0.06	0.07	0.10

- Ceiling

Sound Absorption Coefficient							
Material	125Hz	250Hz	500Hz	1000Hz	2000Hz	4000Hz	NRC
Concrete	0.01/0.1 2	0.02/0.1 3	0.02/0.1 4	0.02/0.1 5	0.02/0.16	0.02/0.1 7	0.00
Gypsum Board, ½ in. thick in suspension system	0.15/NA	0.10/NA	0.05/NA	0.04/NA	0.07/NA	0.09/NA	0.05
Plywood, 3/8 in. thick	0.28/0.1 2	0.22/0.1 6	0.17/0.2 0	0.09/0.2 4	0.010/0.2 8	0.11/0.3 2	0.015

a. Phenomenological Intentionality:

This space must be warm and inviting while at the same time audible and clear. The design of its interior should exalt its materiality and its acoustic sensibility.

b. Sound:

The sound used in this space will be that of El Yunque itself. Altered in certain areas using wall placement, shape, height and materiality in order to either maximize or minimize sounds in different areas of the lobby.

1. Aural Cleansing Room: A buffer zone between the Lobby and the Pavilion itself, a pallet cleansing for the eyes, nose, and thermal sense as the user is guided through a dark room by the ears and hands.

a. Materiality:

- Walls

Sound Absorption Coefficient							
Material	125Hz	250Hz	500Hz	1000Hz	2000Hz	4000Hz	NRC
Gypsum Board, ½ in. thick in suspension system	0.15/NA	0.10/NA	0.05/NA	0.04/NA	0.07/NA	0.09/NA	0.05
Concrete	0.01	0.01	0.02	0.02	0.02	0.02	0.00

- Floor

Sound Absorption Coefficient							
Material	125H	250H	500H	1000H	2000H	4000H	NRC
	z	z	z	z	z	z	
Concrete	0.01	0.01	0.02	0.02	0.02	0.02	0.00

- Ceiling

Sound Absorption Coefficient							
Material	125H	250H	500H	1000H	2000H	4000H	NRC
	z	z	z	z	z	z	
Plywood, 3/8 in. thick	0.28/ 0.12	0.22/ 0.16	0.17/ 0.20	0.09/0. 24	0.010/ 0.28	0.11/0. 32	0.01 5
Gypsum Board, ½ in. thick in suspension system	0.15/N A	0.10/N A	0.05/N A	0.04/NA	0.07/NA	0.09/NA	0.05

b. Phenomenological Intentionality:

This space is meant to disorientate the spectator by transitioning them from the open ambiance to an enclosed designed experience. These rooms appear before and after every designed space in the Pavilion and have the function of a pallet cleanser for the senses.

c. Sound:

The sounds used in this room will be those of the rainforest itself. As will be seen in the taxonomy of the rainforest, and in the analysis of its soundscape the sounds vary depending on the time of the day. This way the experience will never be the same during a single day. One could enter the pavilion walking to the sounds of bugs while leaving at night walking away from the sounds of coquis.

3. Sound Well: A space for experiencing sound as a disembodied phenomenon rather than a direct experience. In other words, in this room sound will appear to have no origin or direction, it will appear as it is coming from no specific point but from all points simultaneously. A room where sound appears to be separated from space.

a. Materiality:

- Walls

Sound Absorption Coefficient							
Material	125H z	250H z	500H z	1000H z	2000H z	4000H z	NRC
Concrete	0.01	0.01	0.02	0.02	0.02	0.02	0.00
Plywood, 3/8 in. thick	0.28/ 0.12	0.22/ 0.16	0.17/ 0.20	0.09/0. 24	0.010/ 0.28	0.11/0. 32	0.01 5

- Floor

Sound Absorption Coefficient							
Material	125Hz	250Hz	500Hz	1000H z	2000Hz	4000H z	NRC
Concrete	0.01	0.01	0.02	0.02	0.02	0.02	0.00

- Ceiling

Sound Absorption Coefficient							
Material	125H z	250H z	500H z	1000H z	2000H z	4000H z	NRC
Steel	0.14/0. 20	0.14/0. 25	0.14/0. 30	0.14/0.3 5	0.16/0.4 0	0.16/0.4 5	0.10

- Phenomenological Intentionality:

Sound as I will explain during the sound mapping of the site has different hierarchies in different plains of altitude. Different animals, vegetation and wind patterns are functions of specific heights. This room is meant to compress these distances into a single space giving the listener a momentary experience of the totality of sound in a singular plain.

- Sound:

A 360-degree reverberation of the sound in El Yunque.

- Sound Bridge: Meant to act as the eye lid for the ears, in this room the user must walk towards sound rather than having sound arrive to them. The bridge is layered by W foam panels giving an eerie sense of silence until reaching the glass end.

- Materiality:

- Walls

Sound Absorption Coefficient							
Material	125H z	250H z	500H z	1000H z	2000H z	4000H z	NRC
VHF Ferrite absorber Panels	0.35/ 0.26	0.35/ 0.13	0.25/ 0.18	0.20/0. 20	0.020/ 0.18	0.22/0. 20	0.20 14

- Floor

Sound Absorption Coefficient							
Material	125Hz	250Hz	500Hz	1000H z	2000Hz	4000H z	NRC
VHF Ferrite absorber Panels	0.35/0 .26	0.35/0. 13	0.25/0. 18	0.20/0. 20	0.020/0. 18	0.22/0. 20	0.2014

- Ceiling

Sound Absorption Coefficient							
Material	125H z	250H z	500H z	1000H z	2000H z	4000H z	NRC
VHF Ferrite absorber Panels	0.35/ 0.26	0.35/ 0.13	0.25/ 0.18	0.20/0. 20	0.020/ 0.18	0.22/0. 20	0.20 14

b. Phenomenological Intentionality:

The experience is meant to give the spectator the ability to tune in and out of the aural arena of the Yunque using architectural and acoustic design.

2. Anechoic Chamber: A room used mainly for acoustic testing, using specialized foam substances it can cancel external sounds and the reverberation of internal reverberation. These rooms are often described as uncomfortable, given enough time the spectator will begin to hear his heart pounding, blood rushing and neurons firing looking for sound.

a. Materiality:

- Walls

Sound Absorption Coefficient							
Material	125H z	250H z	500H z	1000H z	2000H z	4000H z	NRC
VHF Ferrite absorber Panels	0.35/ 0.26	0.35/ 0.13	0.25/ 0.18	0.20/0. 20	0.020/ 0.18	0.22/0. 20	0.20 14
Frankosorb Short pyramid absorber series	0.55/ 0.40	0.45/ 0.35	0.50/ 0.30	0.45/0. 40	0.40/0. 30	0.45/0. 25	0.43 32

- Floor

Sound Absorption Coefficient							
Material	125Hz	250Hz	500Hz	1000H z	2000Hz	4000H z	NRC
VHF Ferrite absorber Panels	0.35/0 .26	0.35/0. 13	0.25/0. 18	0.20/0. 20	0.020/0. 18	0.22/0. 20	0.2014

- Ceiling

Sound Absorption Coefficient							
Material	125H z	250H z	500H z	1000H z	2000H z	4000H z	NRC
VHF Ferrite absorber Panels	0.35/ 0.26	0.35/ 0.13	0.25/ 0.18	0.20/0. 20	0.020/ 0.18	0.22/0. 20	0.20 14
Frankosorb Short pyramid absorber series	0.55/ 0.40	0.45/ 0.35	0.50/ 0.30	0.45/0. 40	0.40/0. 30	0.45/0. 25	0.43 32

b. Phenomenological Intentionality:

In juxtaposition to the Yunquest vast aural arena the Anechoic chamber's acoustic properties place the person in the experience as the aural focus of the room. This internal sensorial experience can be daunting given the rush of sound that was experienced before entering and the rush of sound that will come after.

The proposed location of the project is set in the archipelago of Puerto Rico, in the island of Puerto Rico, which can be seen in the figure 14 in bright pink, at the tropical rain forest of El Yunque, as can be seen in figure 15A, 15B & 16 between San Juan and Luquillo. The proposed site was chosen because of the mountain's natural acoustic richness, coupled with the beauty of the rainforest's visuals, smells and often low temperature. Rainforest's also include another important sensorial experience that is implicit in its name, the high probably of rain as can be seen in figure 17, the gradience from blue to red express the amount of precipitation in millimeters, red being a low amount and blue being the highest on the scale.

Site & Context: Archipelago of Puerto Rico
Scale: N/A



Figure 14 The island of Puerto Rico in bright pink.

Site & Context: Island of Puerto Rico
Scale: N/A

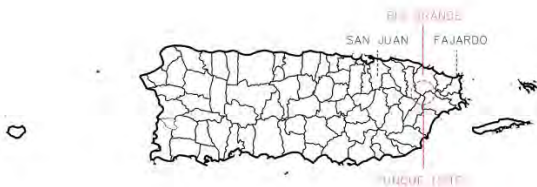

Figure 15A The chosen site can be found in a part of El Yunque between Luquillo and San Juan in Rio Grande

Site & Context: Rio Grande
Scale: N/A



Figure 15B The chosen site can be found in a part of El Yunque between Luquillo and San Juan in Rio Grande

Site & Context: Rio Grande
Scale: N/A



Figure 16. Delimitations of el Yunque in Rio Grande, most of the tropical forest is distributed between other municipalities.

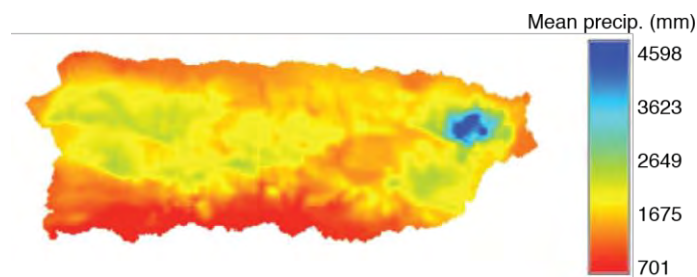

Figure 17. from 1963 to 1995 based on historic observations. (From Daly and other 2003)

The high occurrence of rain in the area allows a duplicity of sensorial experiences targeting our smelling, hearing, and seeing of rain as it interacts with certain materials further cementing the building into the chosen site.

Earcons in the forest also include but are not limited to the sound of animals communicating and the sound of nearby rivers rushing through the mountain, this noise being particularly startling since it can be noticed miles away from the body of water themselves. Additionally, I think it is important to note that the occasional car can be heard passing by occasionally, the noise dissipating as quickly as it arrives. At first, I believed this sound to be a nuisance but later became accustomed to it as it melted into the landscape itself further adding information into the environment through the ear.

Site & Context: Rio Grande

Scale: N/A

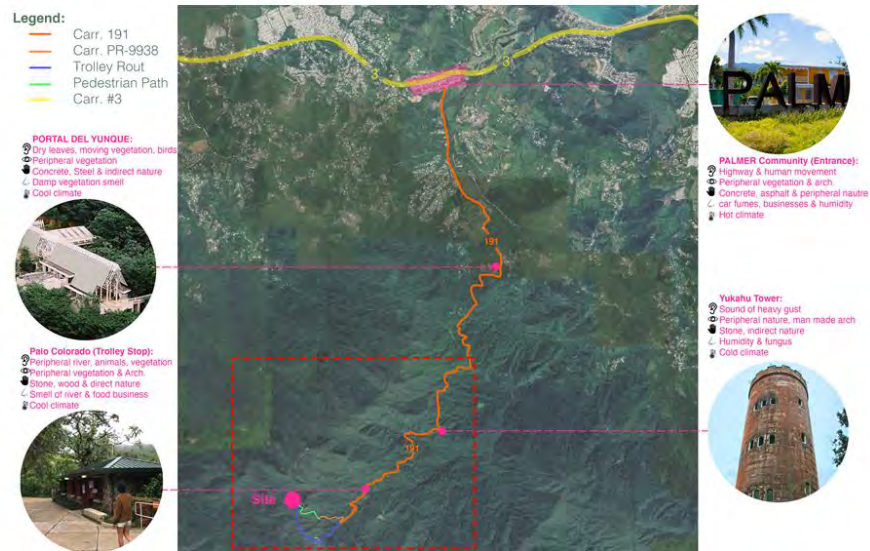

Figure 18. Entrance to the site starts at the Palmer Community and ends in the Mameyes II street.

As can be seen in Figure 18 the chosen sites location is only accessible through the PR-191. The experience, however, begins from the moment one enters the Palmer communities' entrance to el Yunque. The transition from the peripheral sight, smell and sound of nature becomes ever more apparent every marked area as presented in Figure 18. Once you've reached el Portal del Yunque you no longer see concrete buildings as the dominant sight rather nature is dominant above all other sights. The smell of asphalt begins to fade as the rich oxygen of the trees surrounds the visitor inviting them once they've reach the Yukahu Tower or the Palo Colorado station to stop and marvel at the dominance of the rain forest.

Site & Context: Rio Grande

Scale: N/A

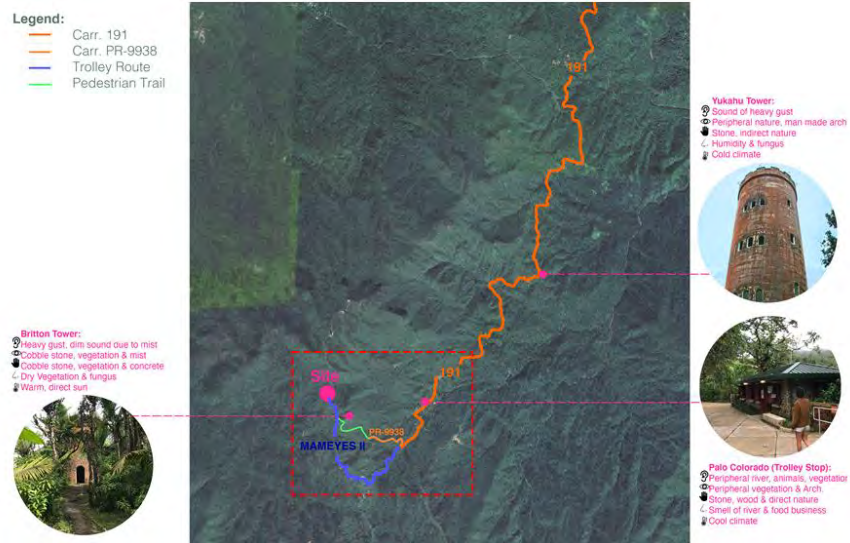

Figure 19. Entrance to the site starts at the Palmer Community and ends in the Mameyes II street.

Once the spectator has reached the Palo Colorado station, he is able to take a trolley to the Site or continue to the PR-9938 towards the Britton path which leads to both the Britton Tower and the Sound Pavilion.

Site & Context: Site Regulations

Scale: N/A

PERMITTED USES

B-Q = A-B (JP 2019)

- "Venta de productos cosechados en la finca incluyendo madera y productos de madera. El espacio de un edificio no > 75m cuadrados."
- "Edificios y usos accesorios relacionados a los usos principales."
- "Construcción de caminos y establos para caballos como complemento al deporte de paseos a caballo."
- "Usos artesanales."
- "Facilidades públicas y facilidades recreativas."
- "Agrícolas, principalmente agro-forestería y silvicultura, cultivos hortícolas, algunas empresas pecuarias compatibles (apicultura y acuicultura), según recomendado por el Departamento de Agricultura."
- "Facilidad agro-turística y eco-turística."
- "Hospedajes especializados"
- "Vivienda de 1 o 2 familias por finca."

Figure 22. The permitted uses allow for recreational facilities.

The site is designated B-Q which is now known as A-B by La Junta de Planificación which allows for the construction of public recreational facilities. This however is overlapped by the Federal Governments initiative to create and further develop the areas for eco-tourism.

Site & Context: Site Infrastructure

Scale: N/A



Figure 23. As can be seen in the “plano dotacional” as presented by la Junta de Planificación de Puerto Rico the site currently has no running water or electrical lines.

The site, as can be seen in Figure 23, has no amenities nearby because it is a rainforest. This implies that if a project is to be developed in this area there would need to be a creation of these facilities connecting with the Autoridad de Acueductos y Arcantarillados (AAA) and LUMA or the project would have to be self-sufficient with water capturing capabilities, a septic tank and either wind or solar energy.

Bibliography

Norberg-Schulz, Christian. (1980). "Genius Loci: Towards a Phenomenon of Architecture."

Academy Editions

Frampton, Kenneth. (1981). "Towards a Critical Regionalism: Six Points for an Architecture of Resistance."

Heidegger, Martin. (1993). "Building Dwelling, Thinking." London: Routledge,

Wheeler, Michael, "Stanford Encyclopedia of Philosophy: Martin Heidegger",
seen on 1/3/2020, <http://plato.stanford.edu/entries/heidegger/>.

Heidegger, Martin. (1971). "Poetry, Language, Thought", New York

Blessner, Barry and Salter, Linda-Ruth. (2008). "Aural Architecture: The Missing
Link" The Journal of American Acoustics

Pascual-Leone, Alvaro & Levent, Nina. (2014) "The Multisensory Museum: Cross-Disciplinary
Perspectives on Touch, Sound, Smell, Memory, and Space." Rowman & Littlefield,

Junta de Planificacion. (2020) "Reglamento Conjunto." Gobierno de Puerto Rico

Pasch, Richard J., Andrew B. Penny, and Robbie Berg. "National Hurricane Center Tropical
Cyclone Report: Maria (AL152017)." nhc.noaa.gov. September 30, 2017.

Accessed March 4, 2018. https://www.nhc.noaa.gov/data/tcr/AL152017_Maria.pdf.

Blessner, Barry, (1993) "The Soundscape." Destiny Books; Original ed.

Program

PROGRAM	AREA IN SQUARE FEET
BATHROOMS	358
ENTRYWAY	1,345
SOUND IN CONTEXT (PAVILION INFO CENTER)	220
SOUNDWELL	1,295
SOUND BRIDGE	1,845
ANECHOIC CHAMBER	1,385
IN-BETWEEN AREAS	2,925
UTILITY ROOMS & STORAGE	330
TOTAL	9,720

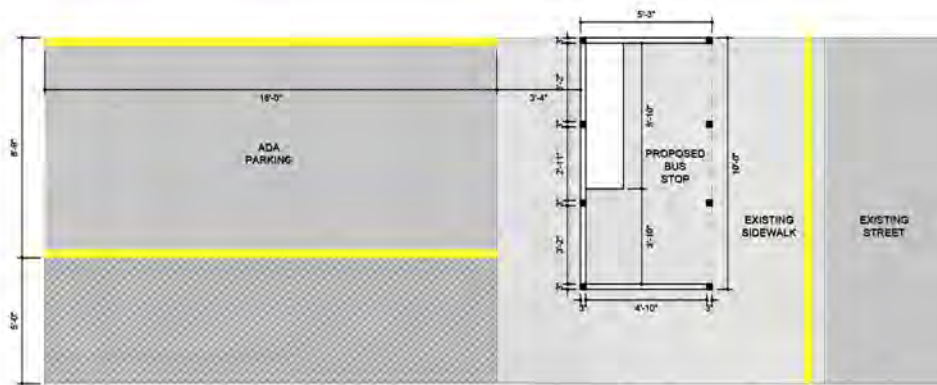

PROPOSED TROLLEY STOP

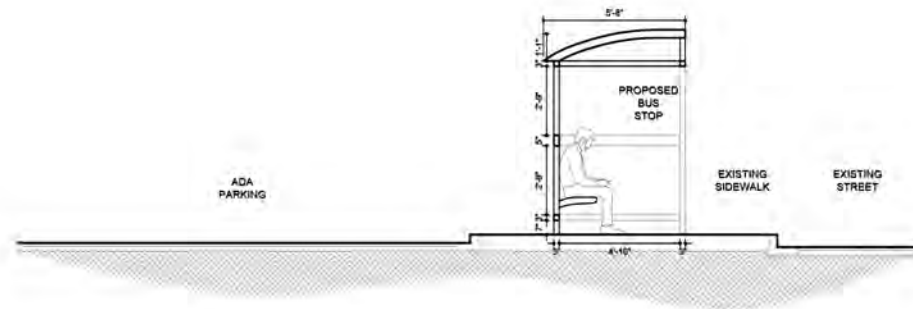

PROPOSED TROLLEY STOP SECTION

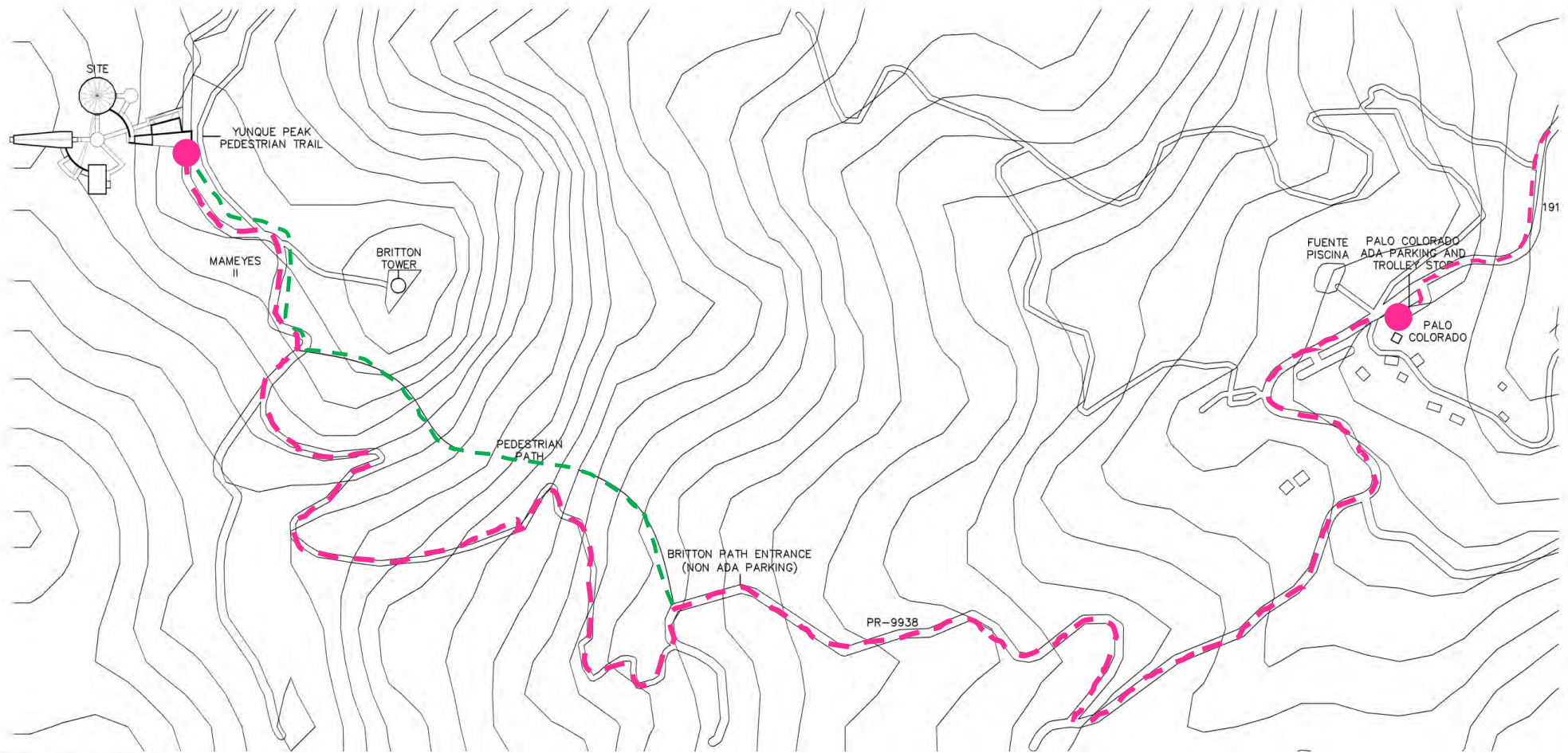

PROPOSED SITE PLAN

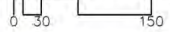

- LEGEND:**
- ▲ 10"x10"x10" TRIANGULAR STRUCTURAL COLUMN
 - 6" STRUCTURAL COLUMN
 - ◻ W Franksorb® pyramid absorbers (fire class A2 and B2) fulfill the requirements for cleanroom compatibility acc. to ISO 14644-1, class 5.
 - ▤ PRE-FAB WALLS WITH CONCRETE WALL WITH STONE FINISH

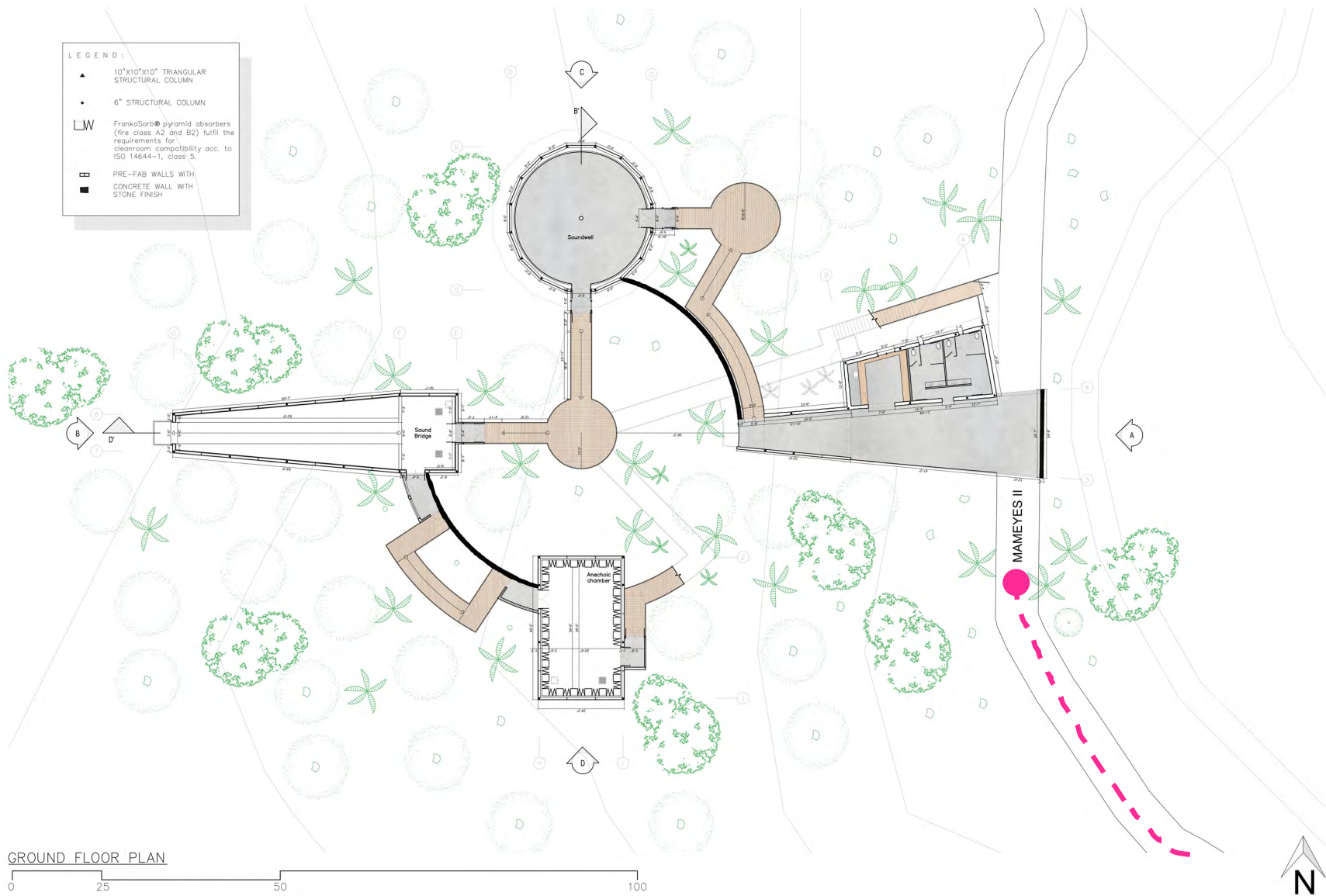

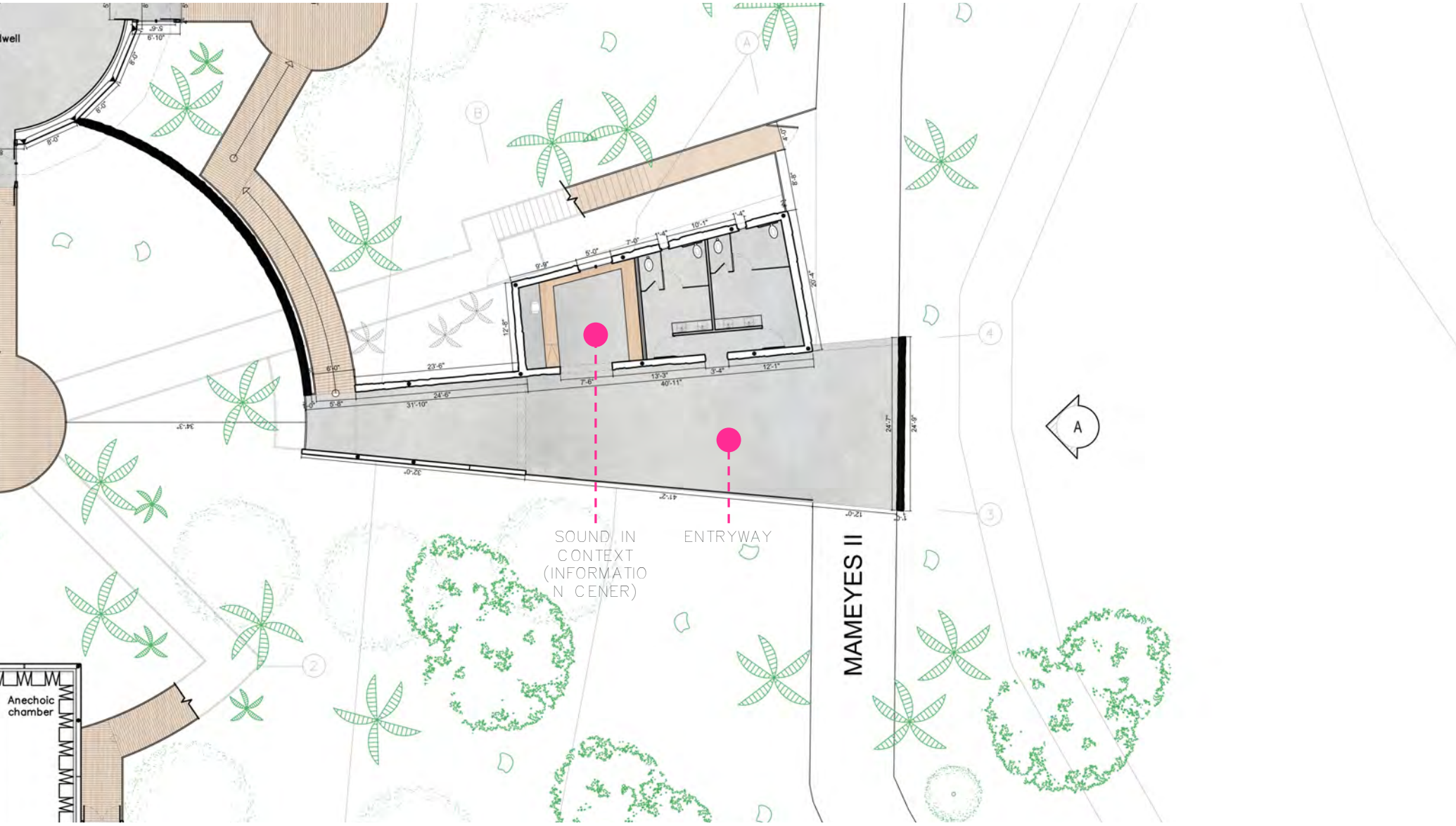

Well

Anechoic chamber

SOUND IN
CONTEXT
(INFORMATION CENTER)

ENTRYWAY

MAMEYES II



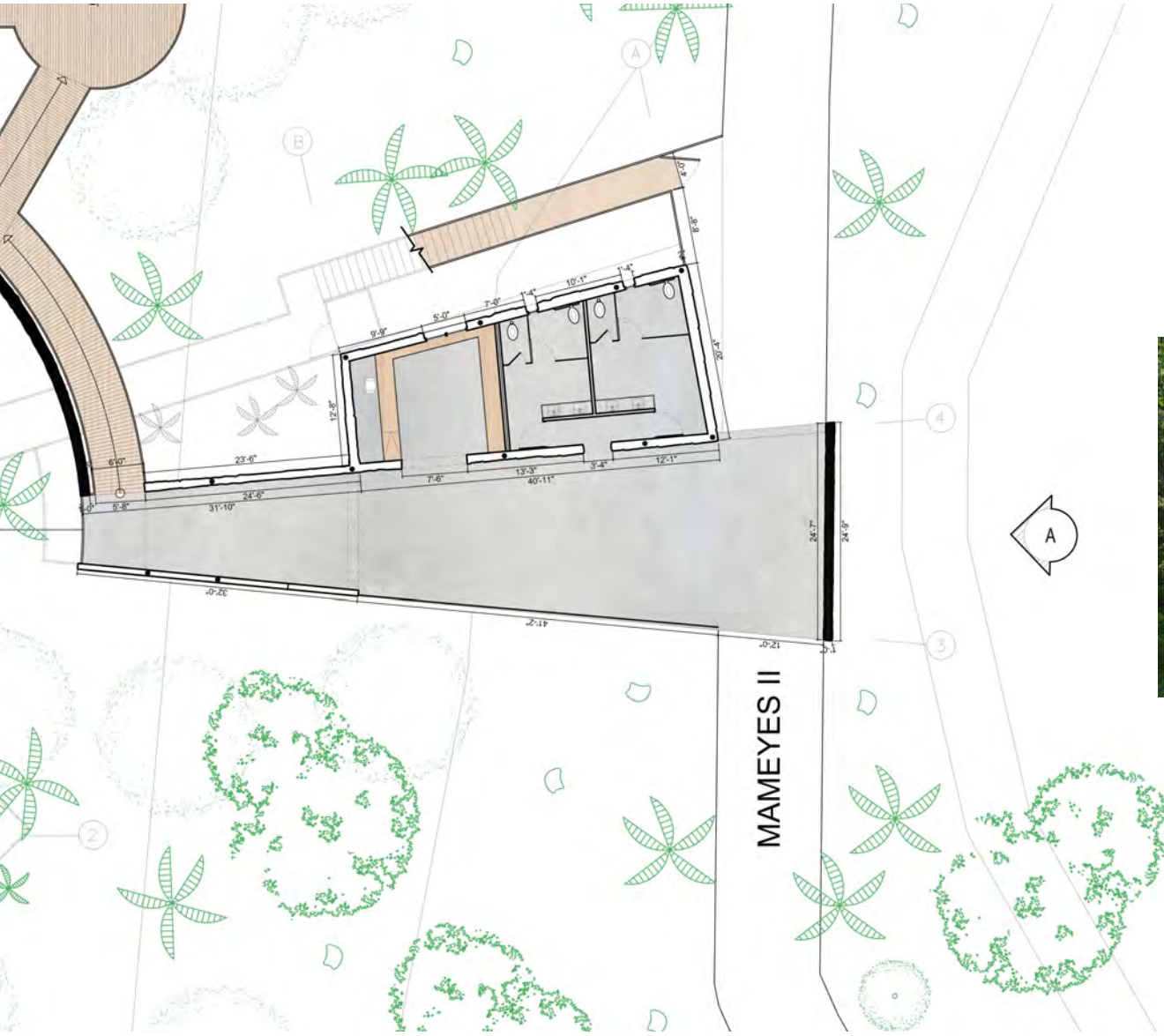

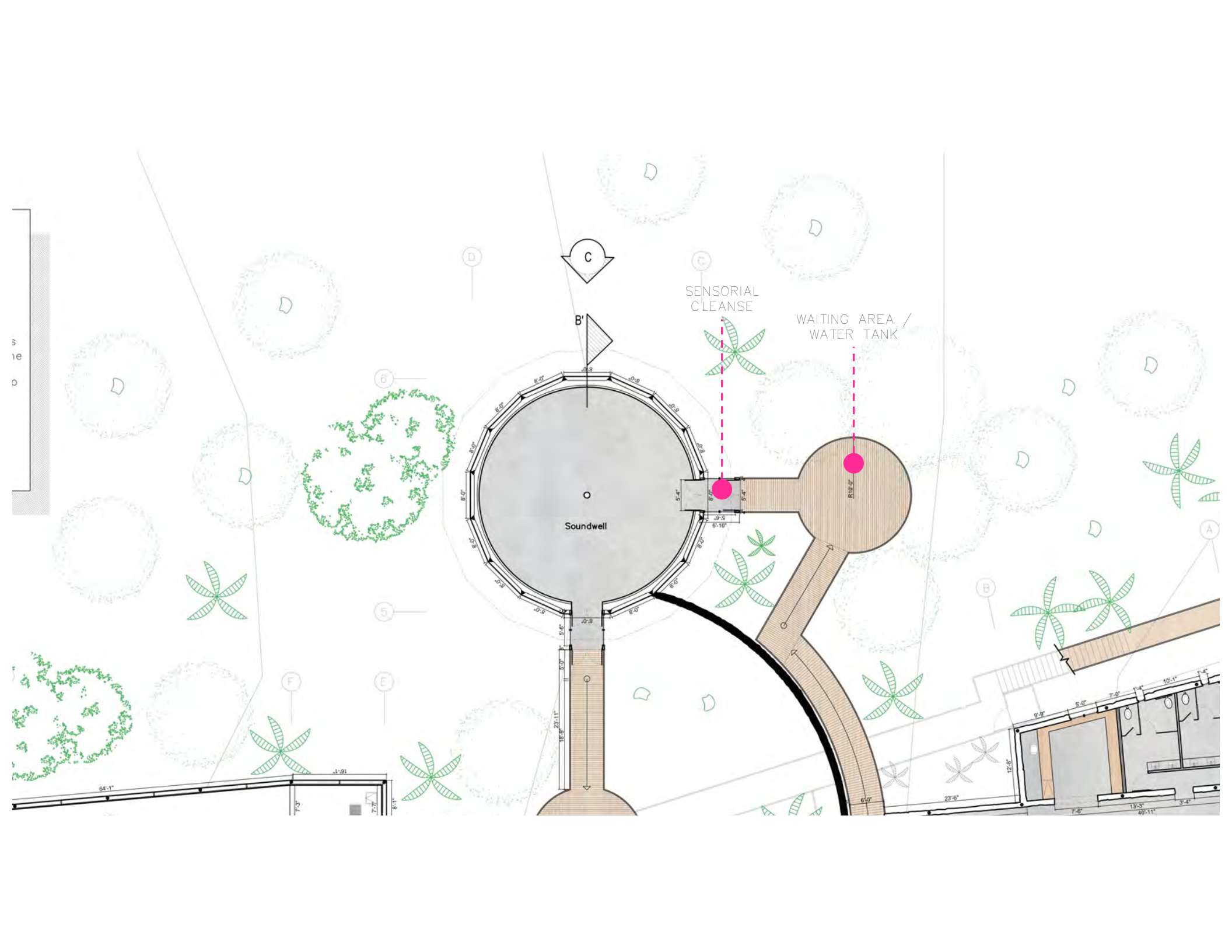

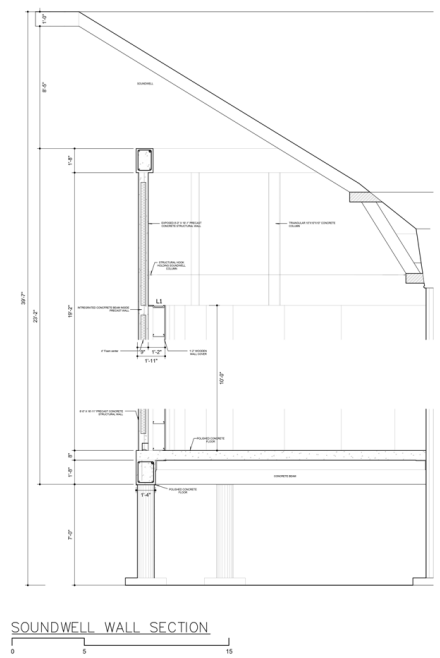
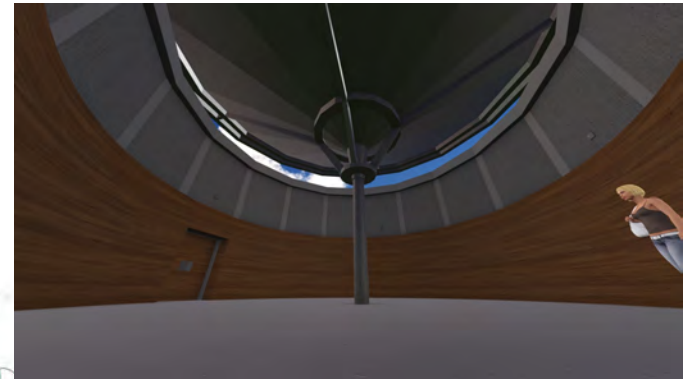
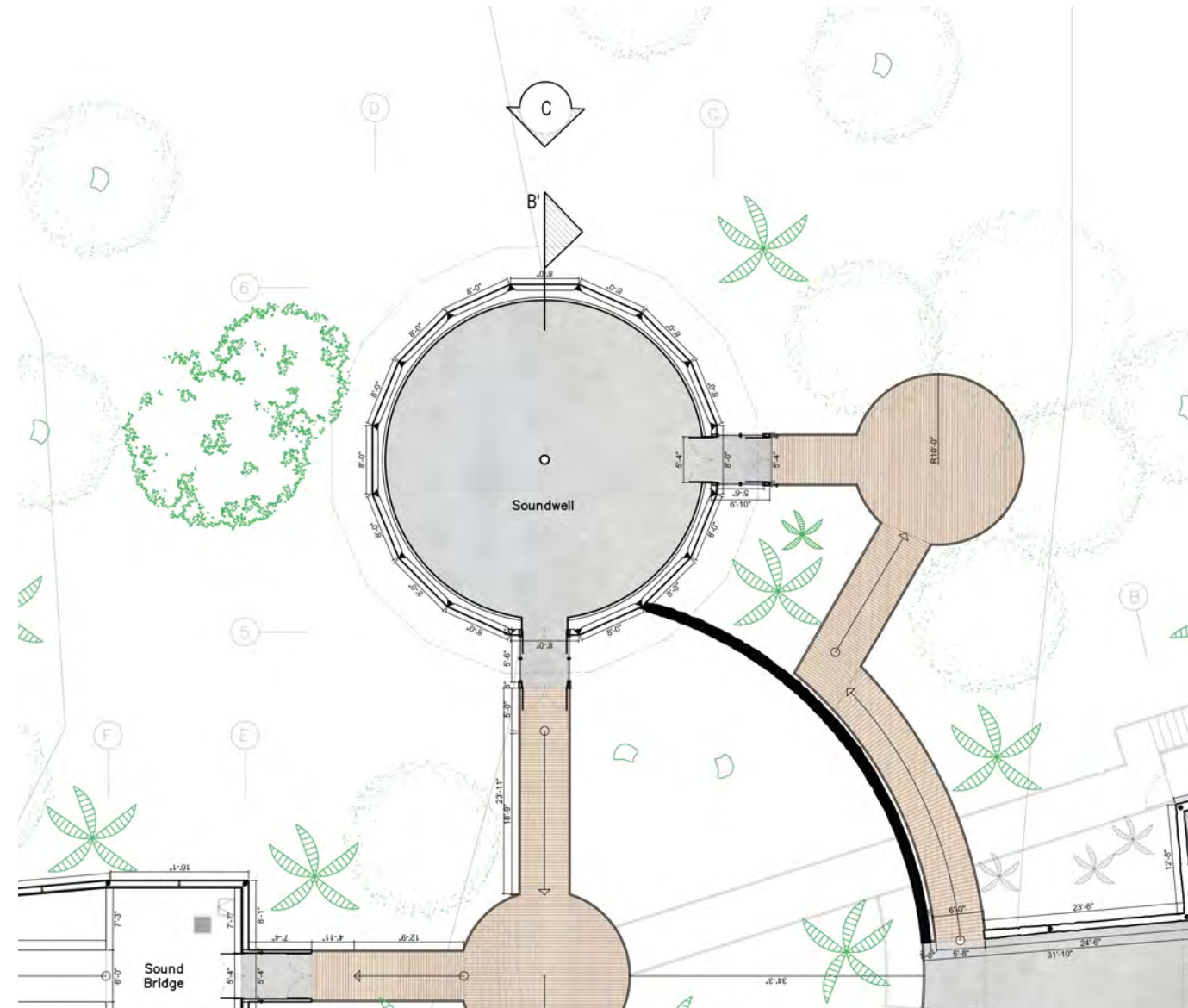

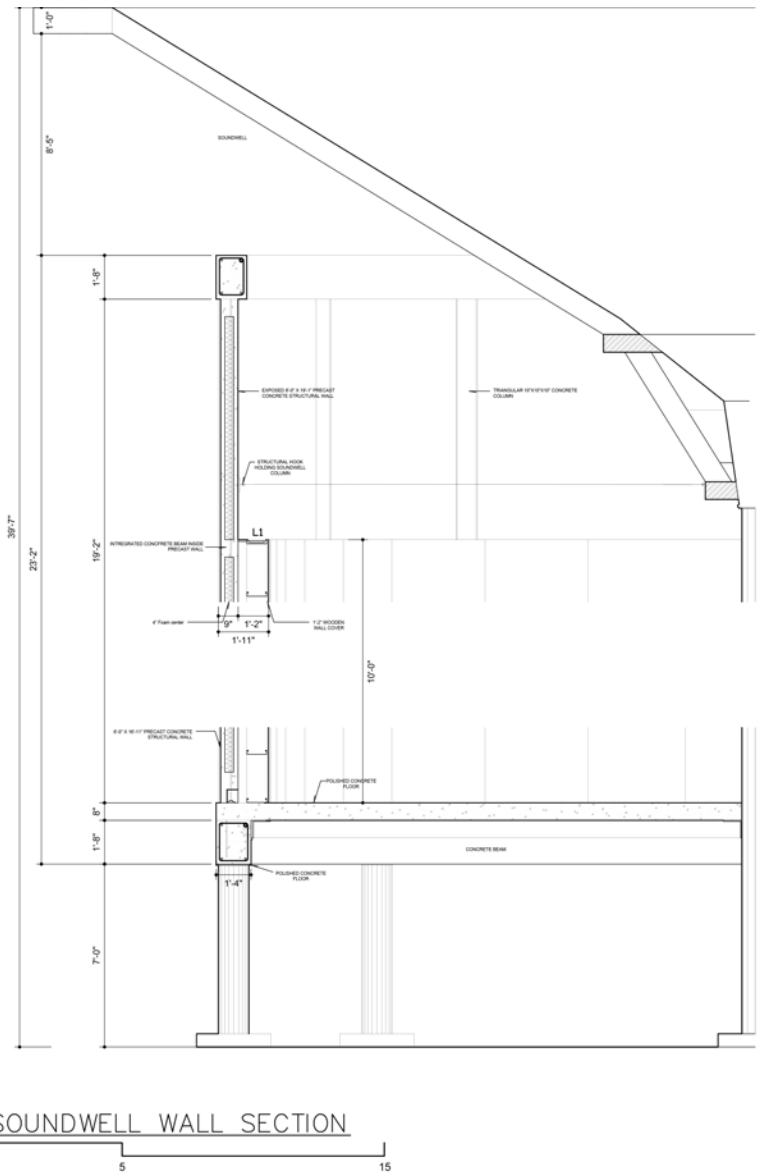
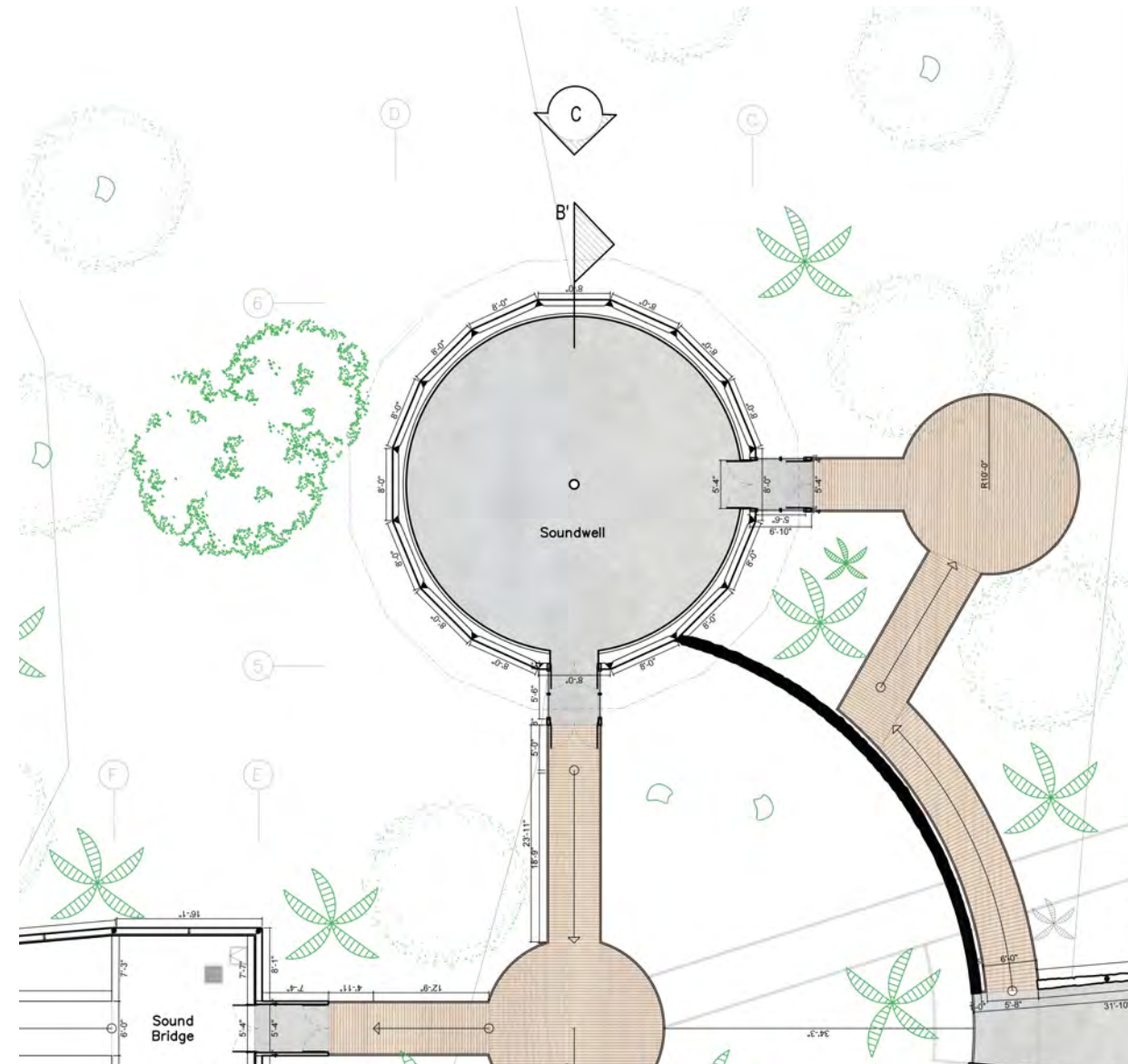

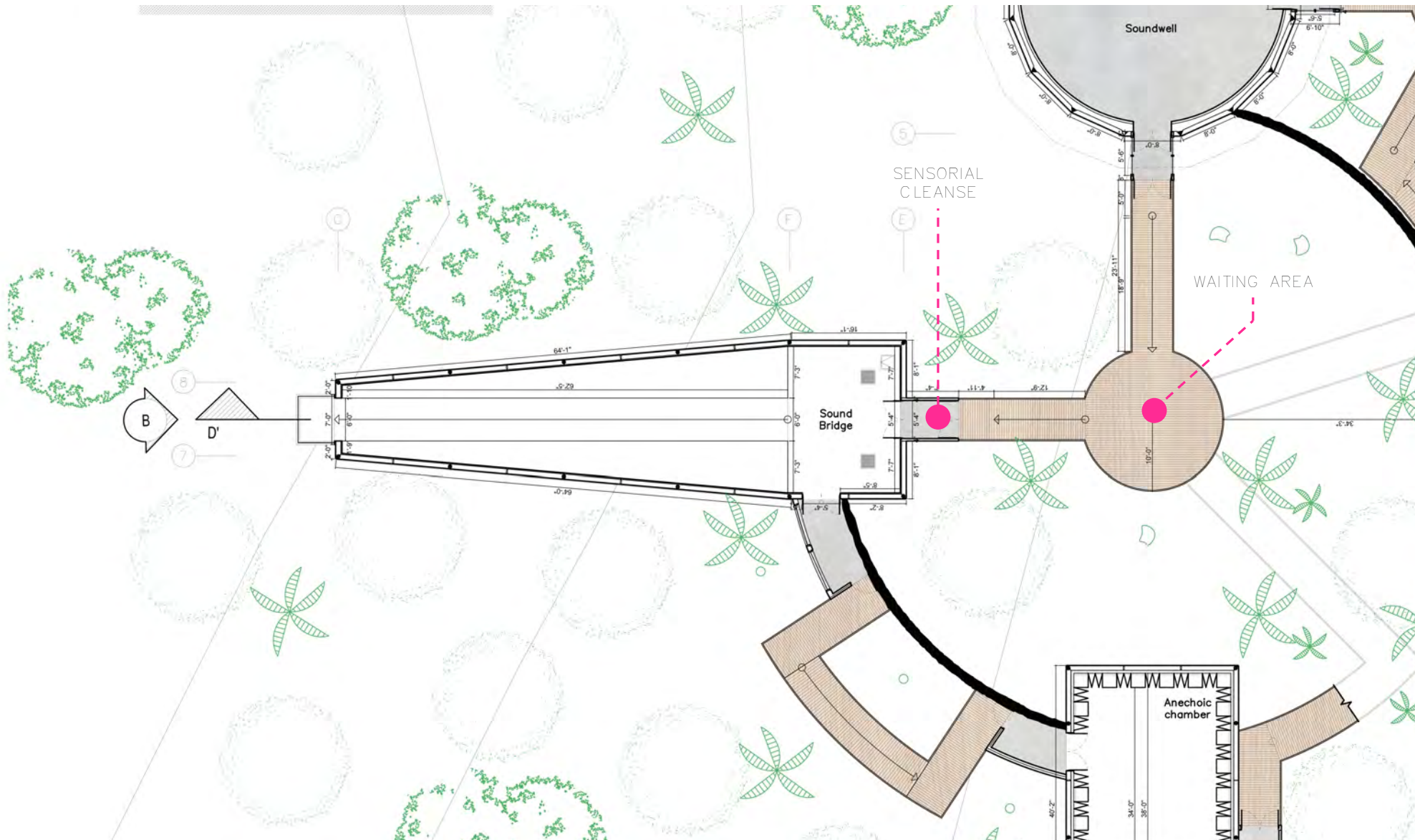

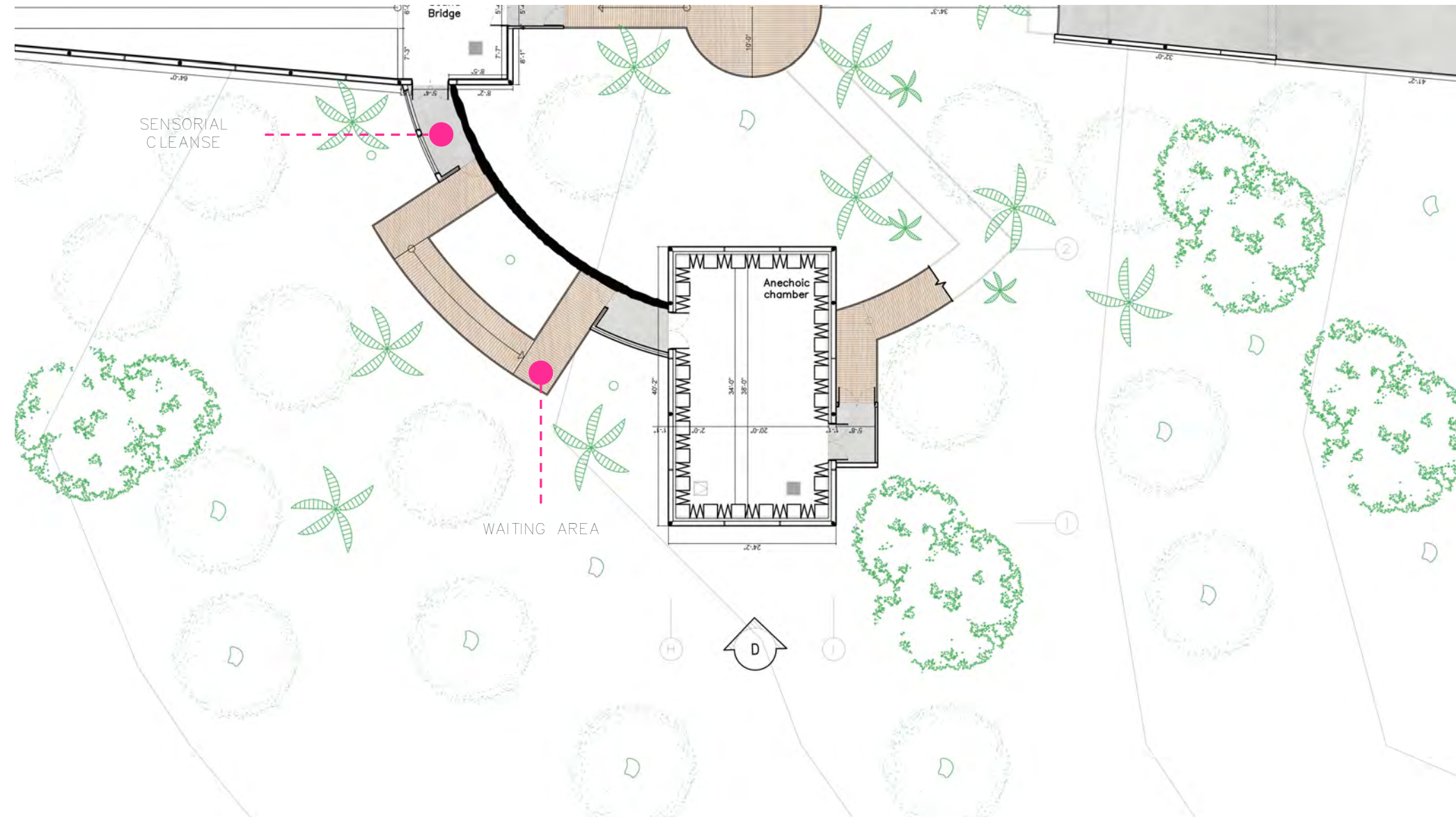

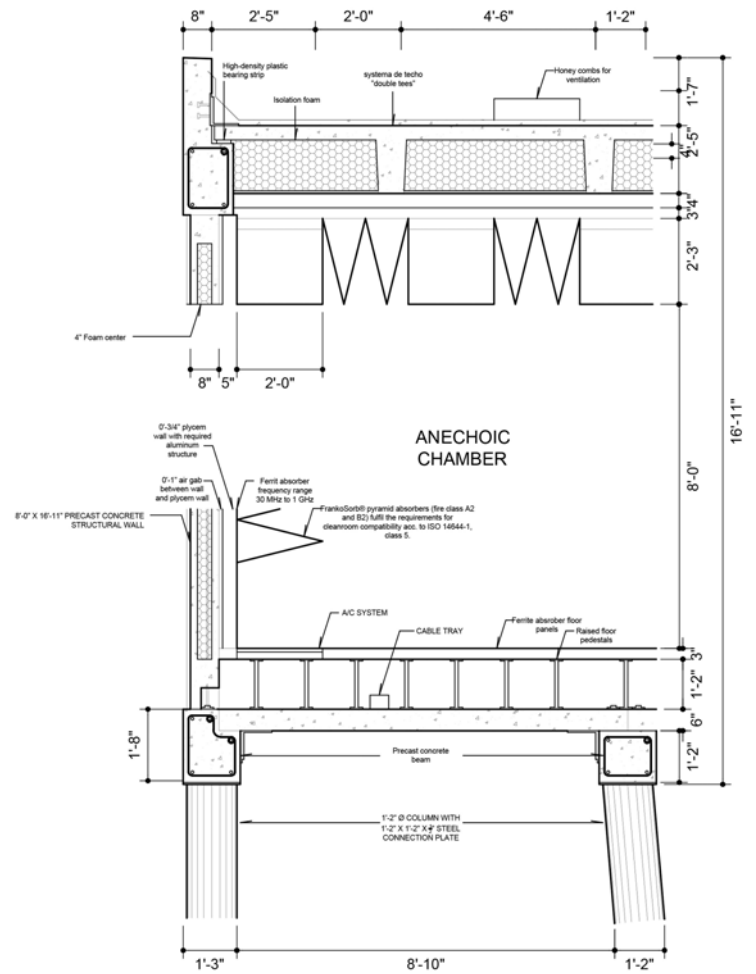
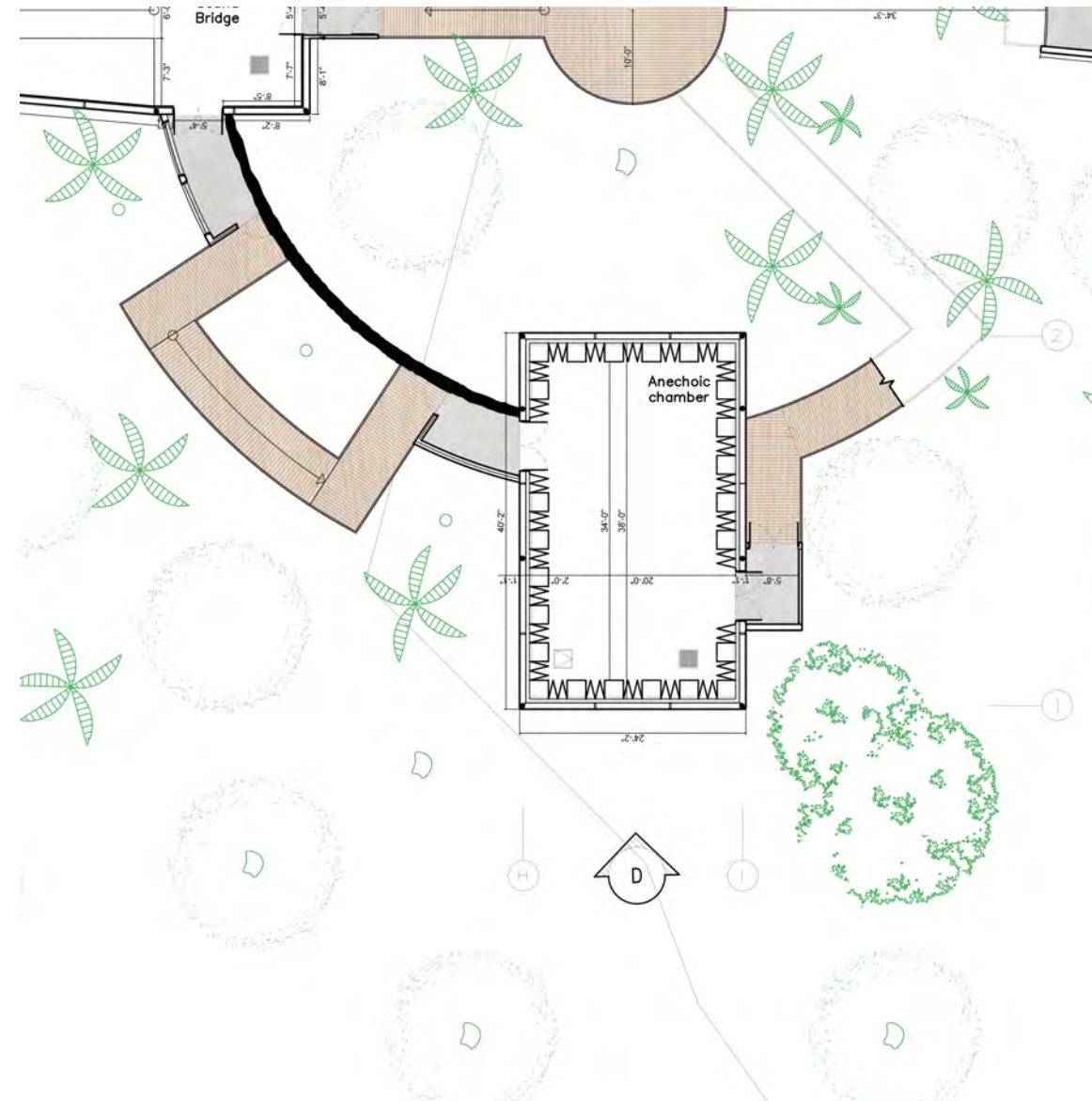

ANECHOIC CHAMBER WALL SECTION



LEGEND:

▲	10"x10"x10" TRIANGULAR STRUCTURAL COLUMN
●	6" STRUCTURAL COLUMN
LW	FrankaSort® pyramis absorbers (fire class A2 and B2) fulfil the requirements for classroom compatibility acc. to ISO 14644-1, class 5.
▤	PRE-FAB WALLS WITH CONCRETE WALL WITH STONE FINISH

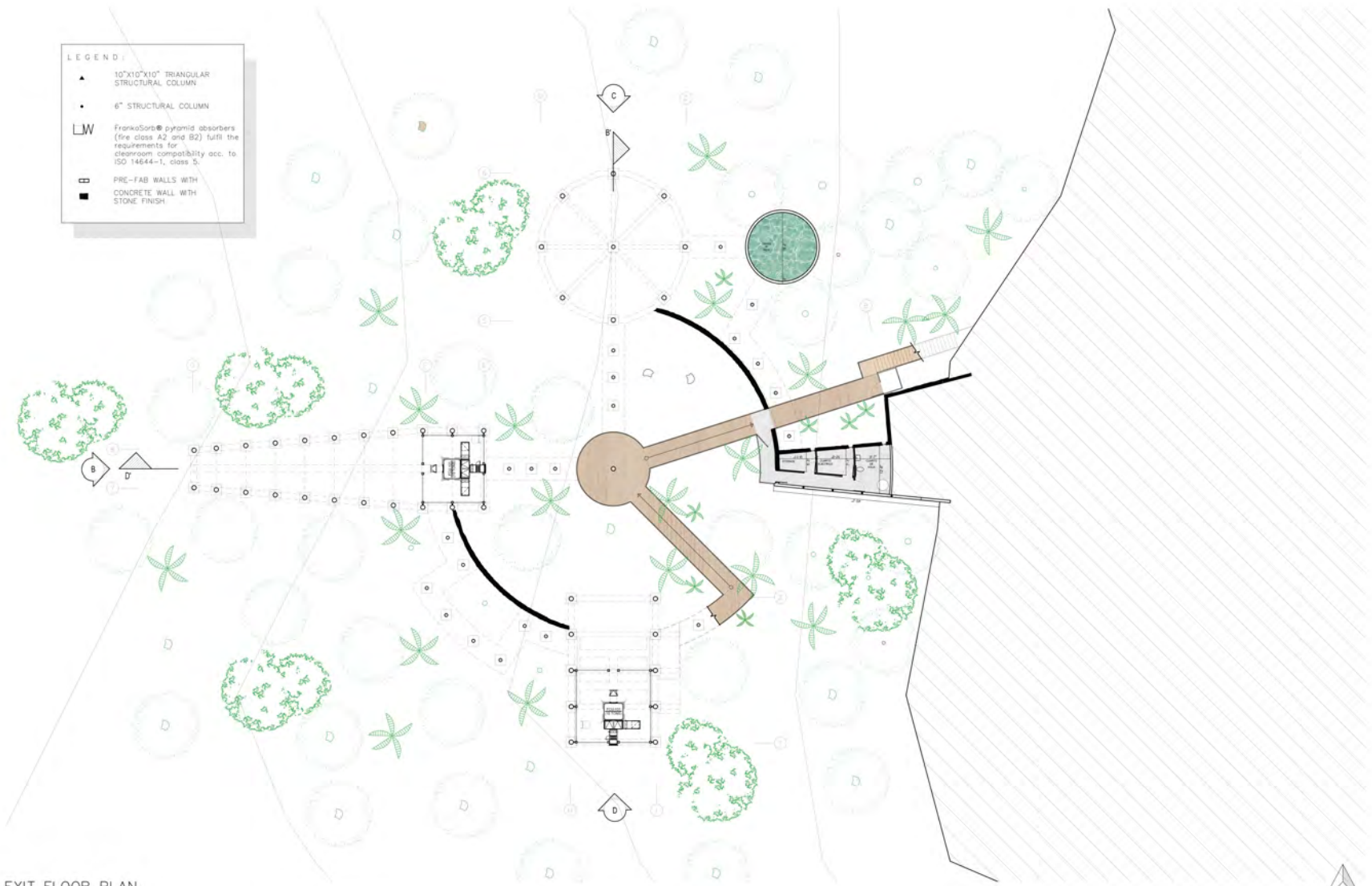

EXIT FLOOR PLAN



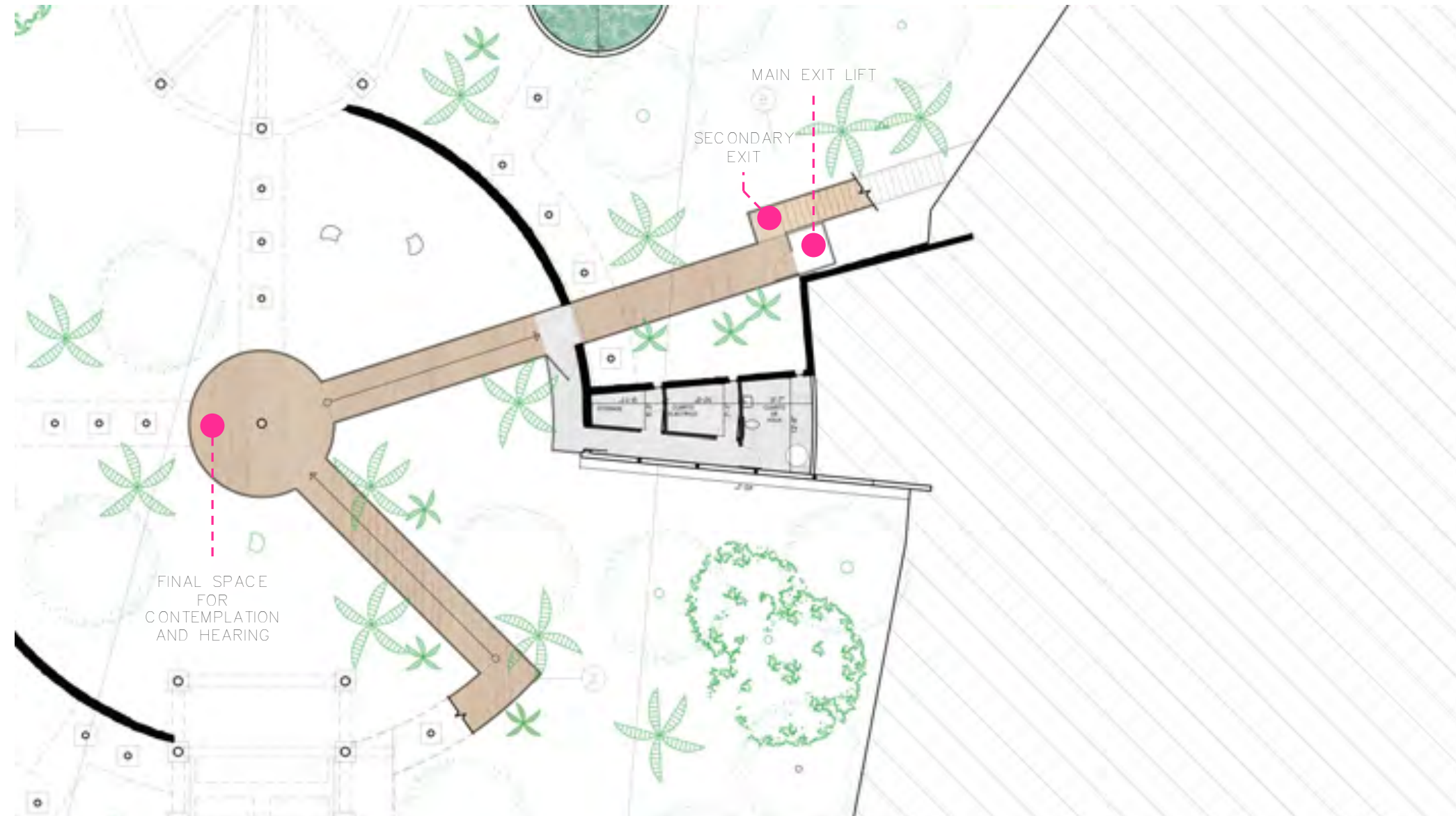

MAIN EXIT LIFT

SECONDARY
EXIT

FINAL SPACE
FOR
CONTEMPLATION
AND HEARING



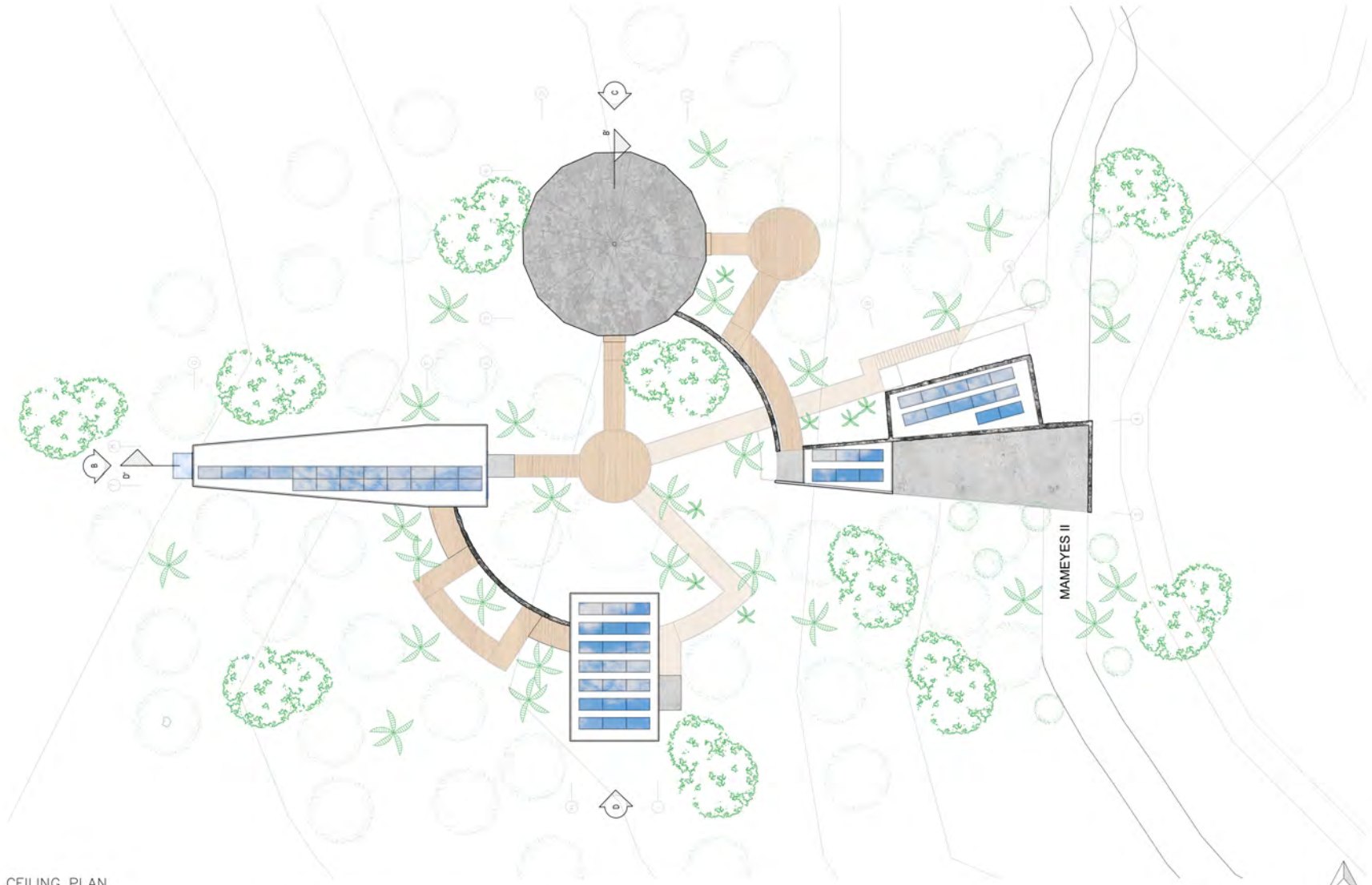

CEILING PLAN

0 25 50 100

MAMEYES II



ANECHOIC CHAMBER

ENTRYWAY

SOUNDWELL

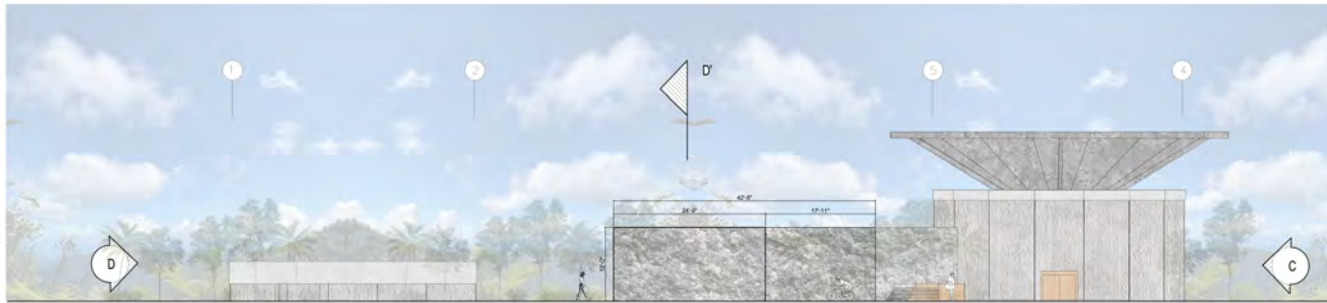

A EAST ELEVATION



SOUNDWELL

SOUNDBRIDGE

ANECHOIC CHAMBER



B WEST ELEVATION

0 25 50 100

ENTRYWAY

SOUNDWELL

SOUNDBRIDGE



C NORTH ELEVATION



SOUNDBRIDGE

ANECHOIC CHAMBER

ENTRYWAY



D SOUTH ELEVATION

0 25 50 100

SOUNDBRIDGE

SOUNDWELL

ENTRYWAY

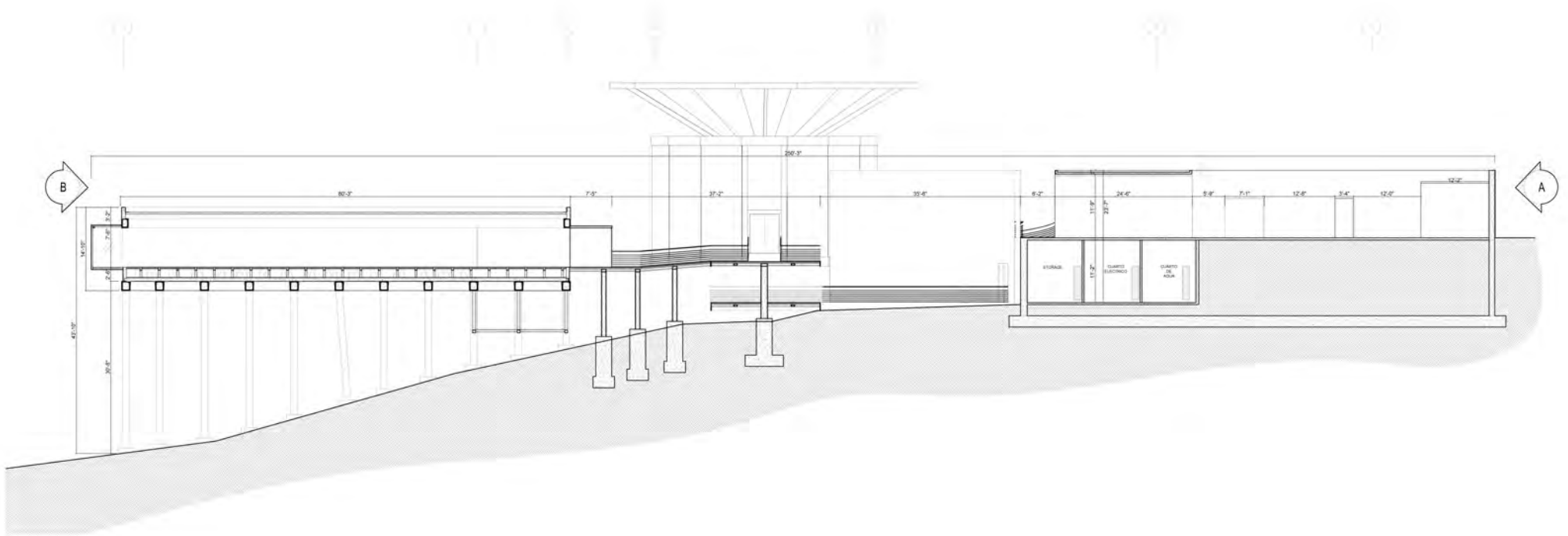

LONGITUDINAL SECTION



SOUNDWELL

ENTRYWAY

ANECHOIC CHAMBER

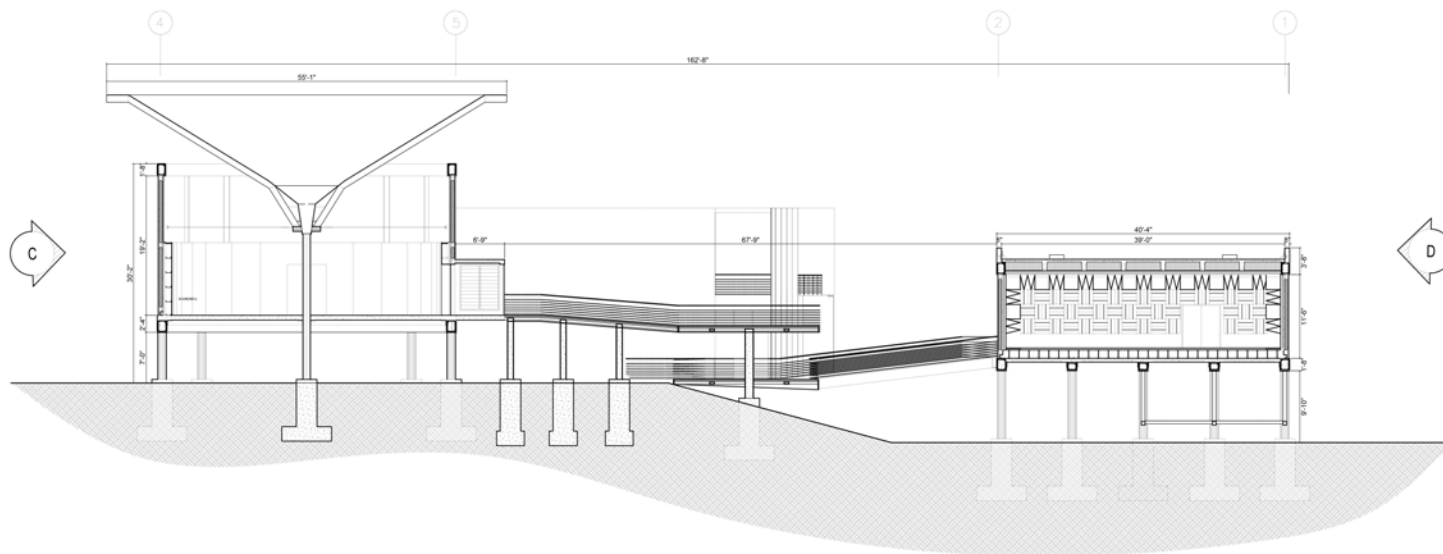

TRANSVERSAL SECTION



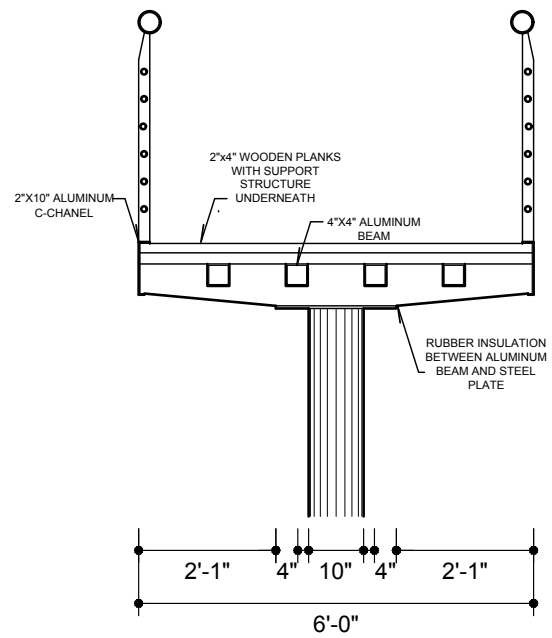
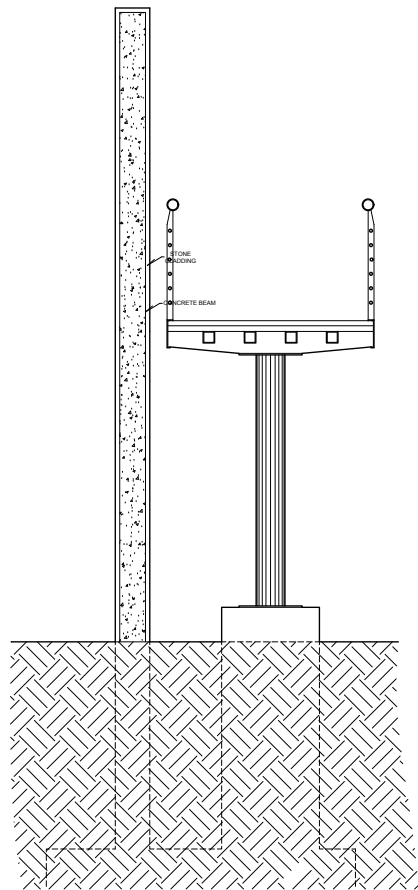

TYP. CONCRETE WALL & BRIDGE SECTION

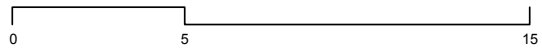

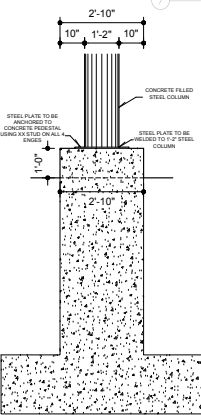
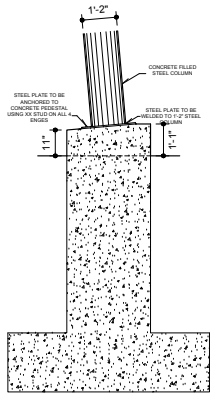

TYP. ALUMINUM BRIDGE DETAIL

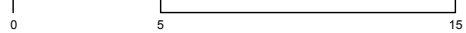

STRUCTURAL PLAN: EXIT FLOOR

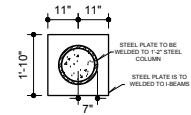
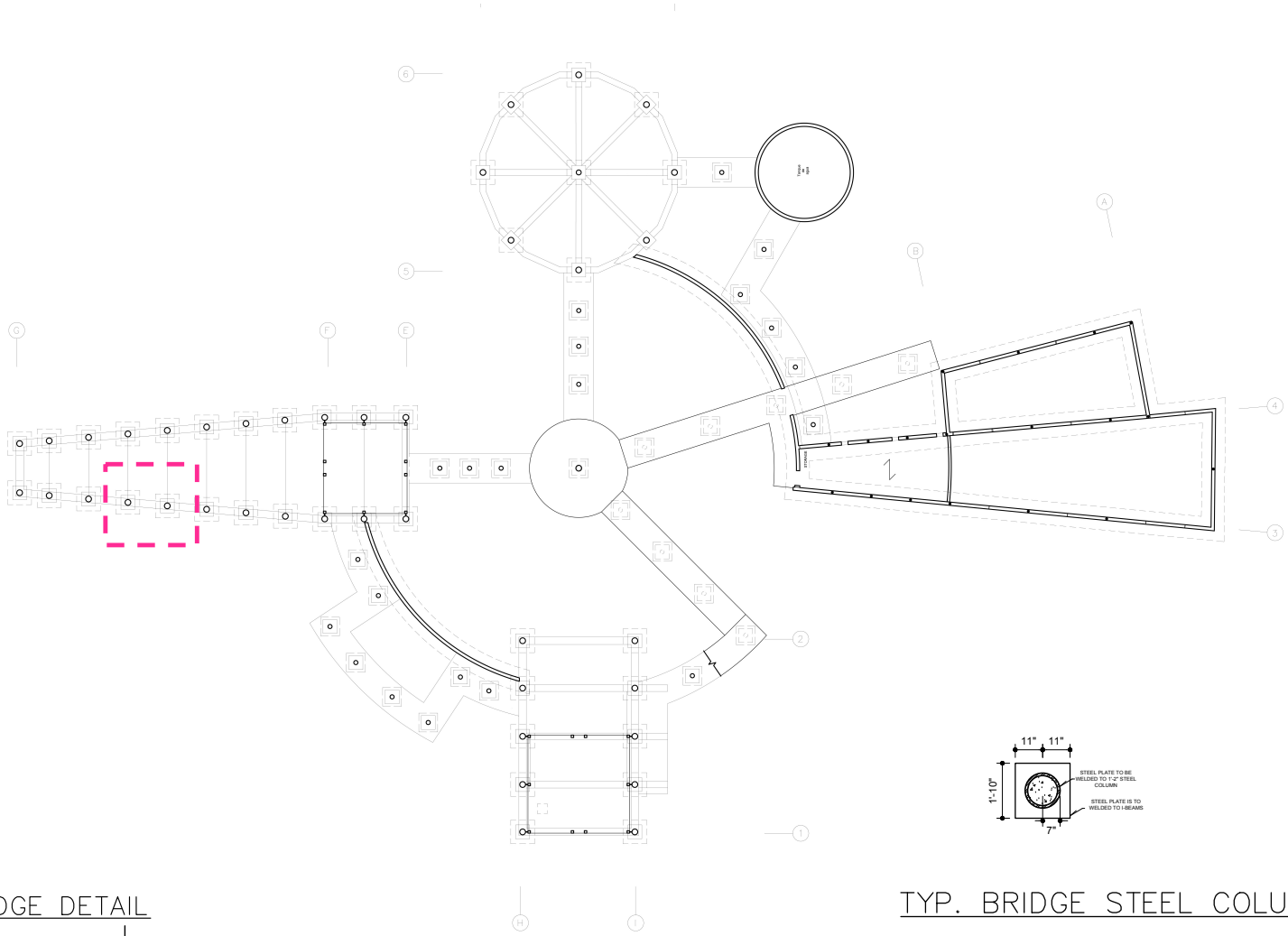

TYP. BRIDGE STEEL COLUMN PLATE



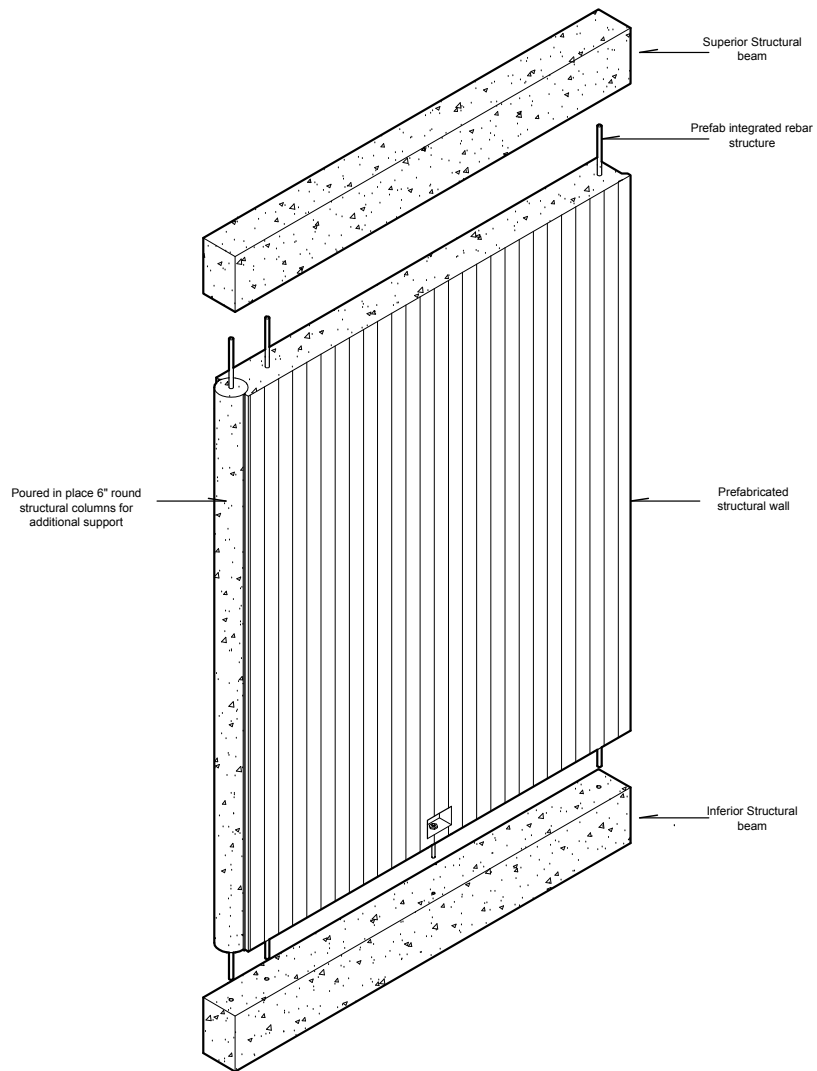

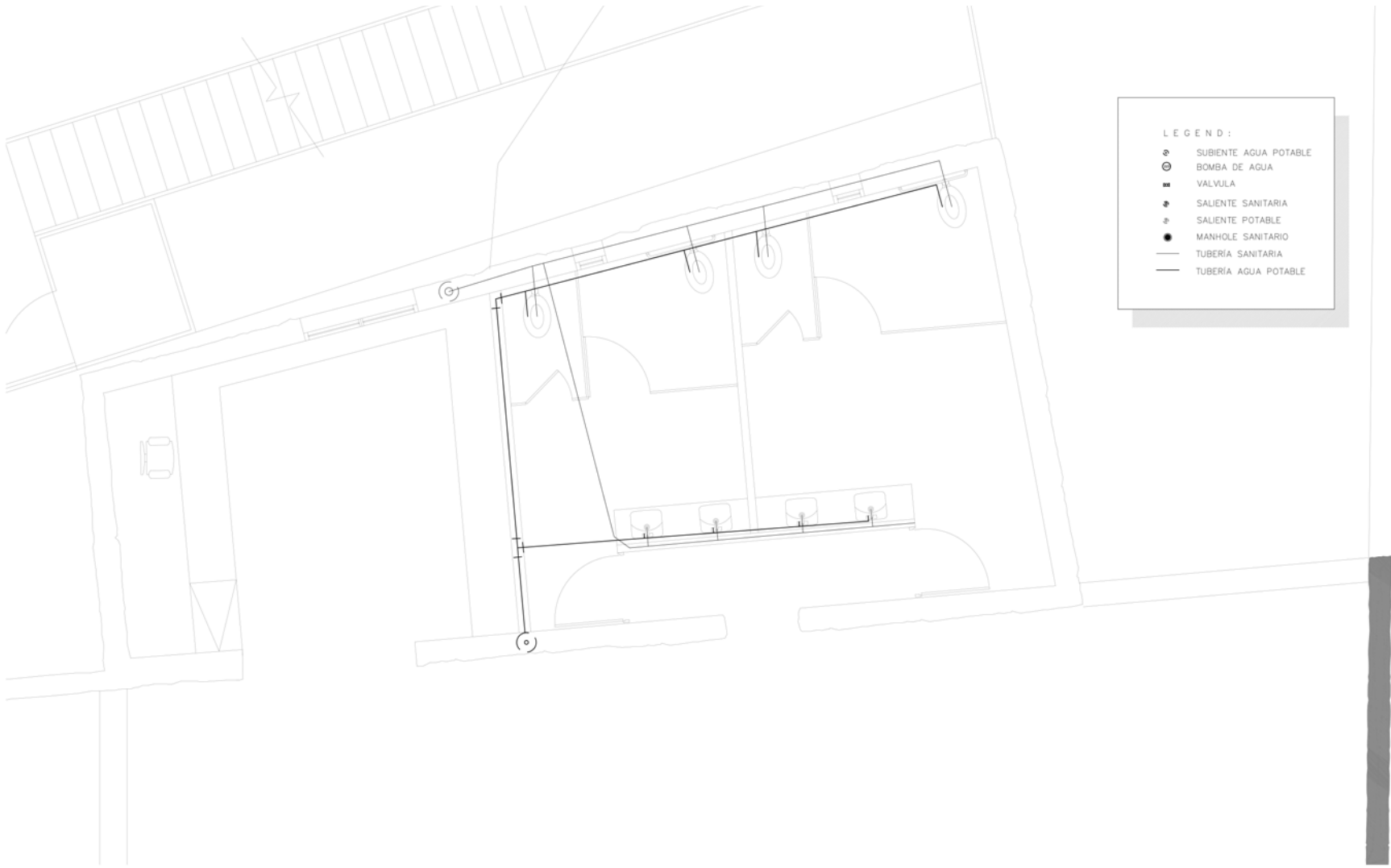

- LEGEND :
- ⊙ SUBIENTE AGUA POTABLE
 - ⊕ BOMBA DE AGUA
 - VALVULA
 - ⊙ SALIENTE SANITARIA
 - ⊙ SALIENTE POTABLE
 - MANHOLE SANITARIO
 - TUBERIA SANITARIA
 - TUBERIA AGUA POTABLE

SANITARY SEWER & POTABLE WATER GROUND FLOOR PLAN



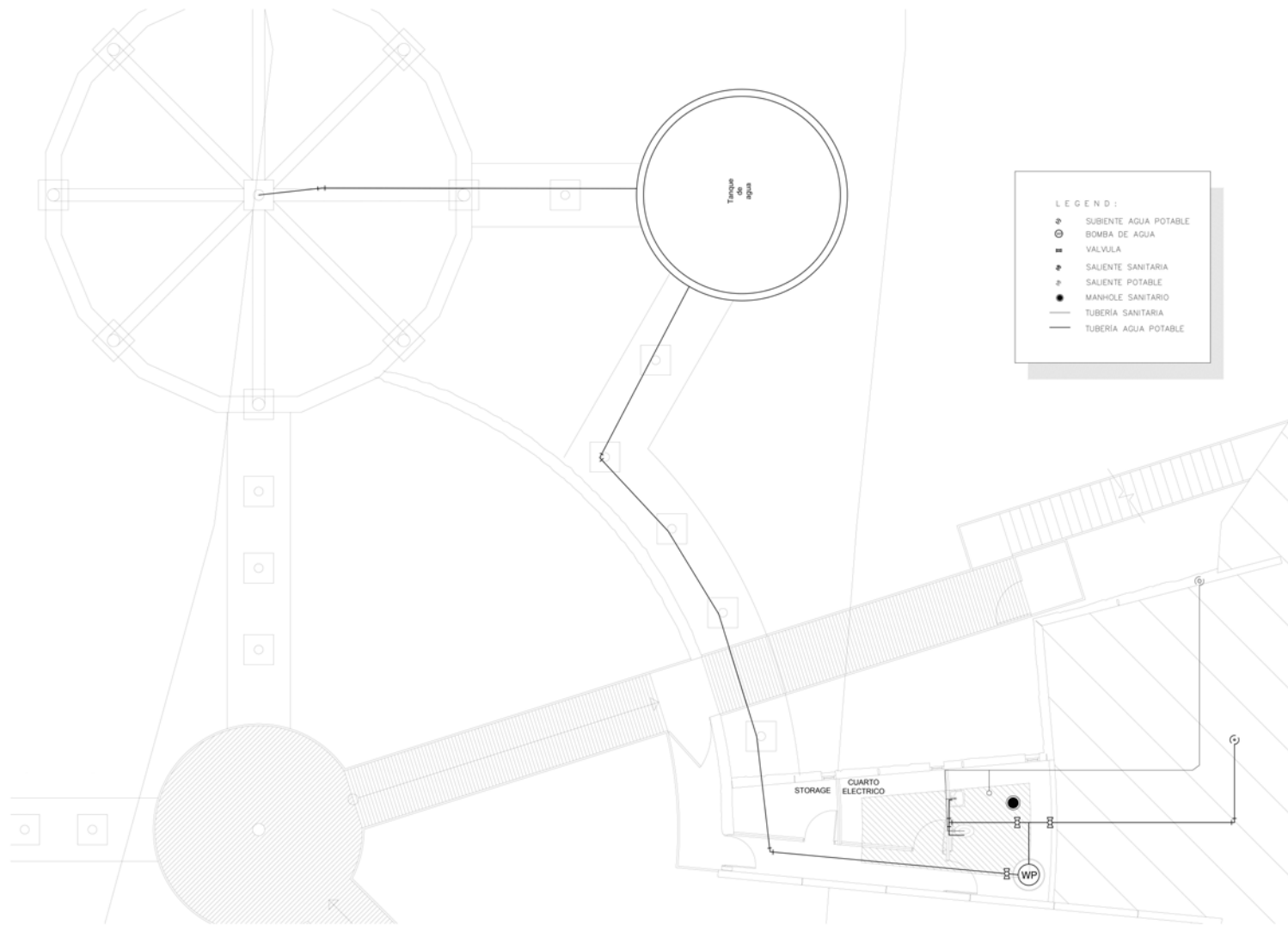



LEGEND:

⊕	SALIENTE AGUA POTABLE
⊙	BOMBA DE AGUA
■	VALVULA
⊕	SALIENTE SANITARIA
⊕	SALIENTE POTABLE
●	MANHOLE SANITARIO
---	TUBERIA SANITARIA
—	TUBERIA AGUA POTABLE

SANITARY SEWER & POTABLE WATER EXIT FLOOR PLAN



LEGEND:

	AIR CONDITIONER
	AIR CONDENSER
	ELECTRIC CONDUIT

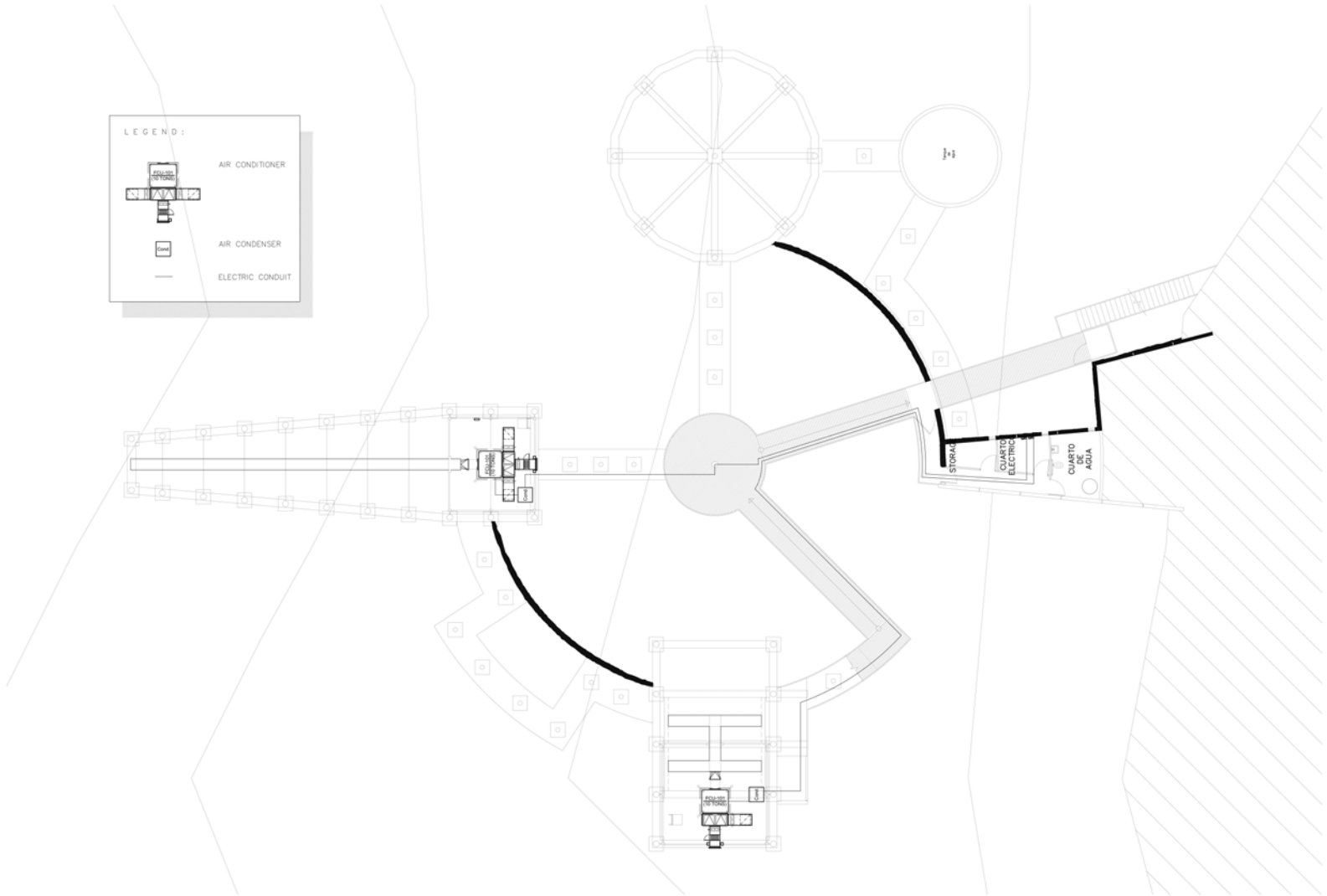

MECHANICAL PLAN



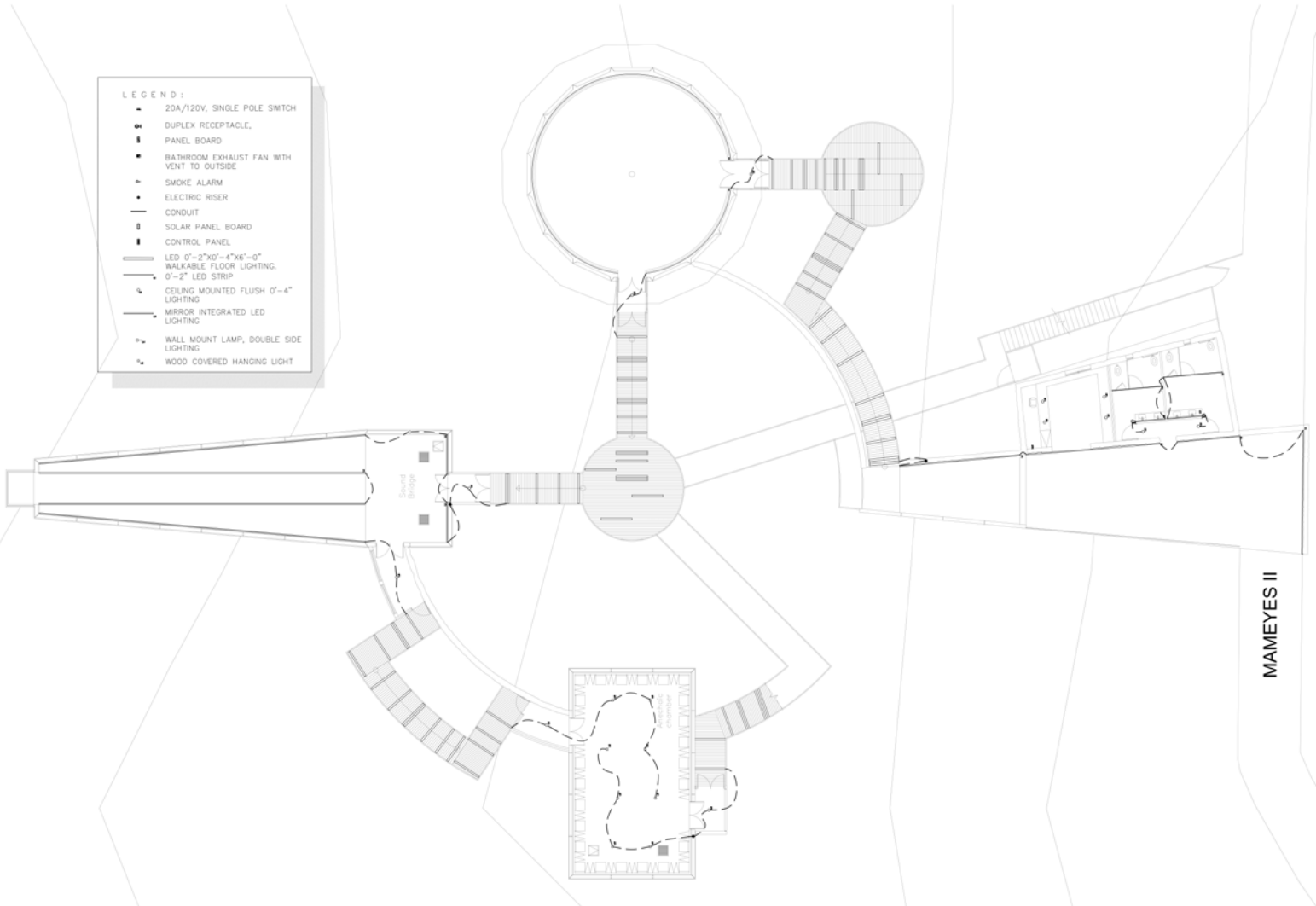

- LEGEND :**
- 20A/120V, SINGLE POLE SWITCH
 - DUPLEX RECEPTACLE
 - PANEL BOARD
 - BATHROOM EXHAUST FAN WITH VENT TO OUTSIDE
 - ▶ SMOKE ALARM
 - ELECTRIC RISER
 - CONDUIT
 - SOLAR PANEL BOARD
 - CONTROL PANEL
 - LED 0'-2"x0'-4"x6'-0" WALKABLE FLOOR LIGHTING
 - 0'-2" LED STRIP
 - ⊥ CEILING MOUNTED FLUSH 0'-4" LIGHTING
 - MIRROR INTEGRATED LED LIGHTING
 - ⊥ WALL MOUNT LAMP, DOUBLE SIDE LIGHTING
 - ⊥ WOOD COVERED HANGING LIGHT

ELECTRIC GROUND FLOOR PLAN



MAMEYES II



- LEGEND:
- 20A/120V, SINGLE POLE SWITCH
 - ⊕ DUPLEX RECEPTACLE
 - ▬ PANEL BOARD
 - BATHROOM EXHAUST FAN WITH VENT TO OUTSIDE
 - ▷ SMOKE ALARM
 - ELECTRIC RISER
 - CONDUIT
 - ▬ SOLAR PANEL BOARD
 - ▬ CONTROL PANEL
 - ▬ LED 0'-2"X0'-4"X6'-0" WALKABLE FLOOR LIGHTING
 - ▬ 0'-2" LED STRIP
 - ⊕ CEILING MOUNTED FLUSH 0'-4" LIGHTING
 - ▬ MIRROR INTEGRATED LED LIGHTING
 - ▷ WALL MOUNT LAMP, DOUBLE SIDE LIGHTING
 - WOOD COVERED HANGING LIGHT

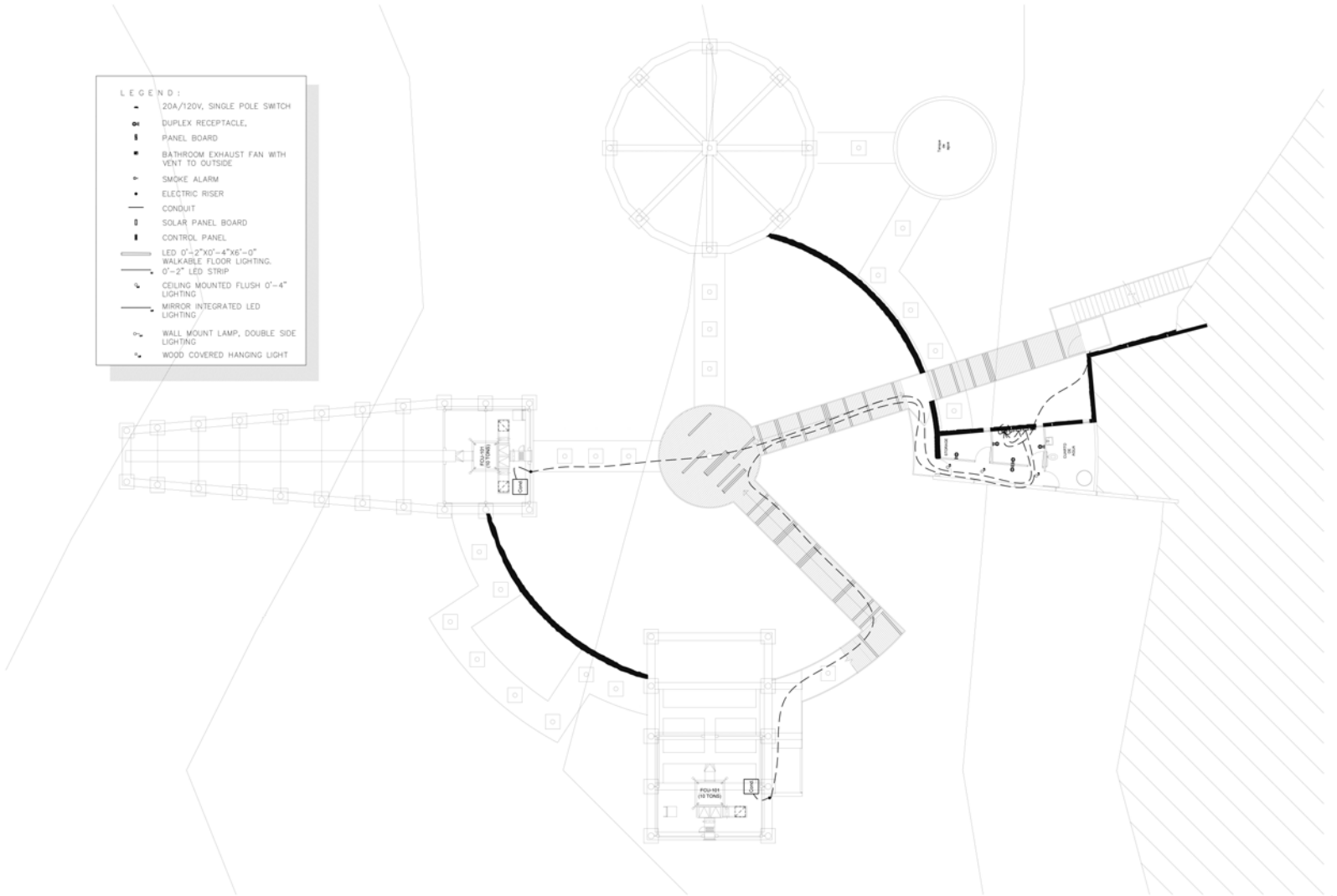

ELECTRIC EXIT FLOOR PLAN



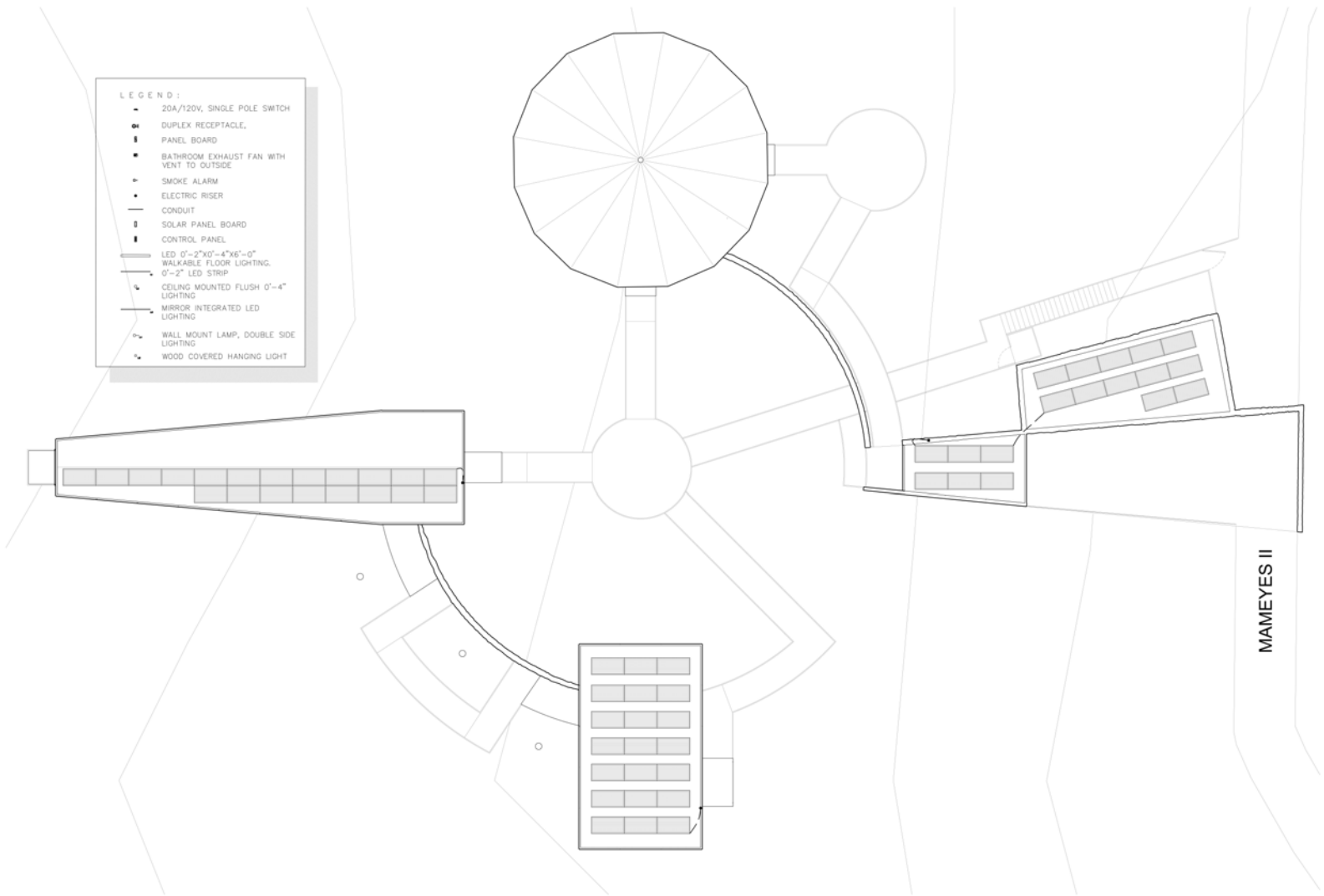

- LEGEND:**
- 20A/120V, SINGLE POLE SWITCH
 - ⊕ DUPLEX RECEPTACLE
 - PANEL BOARD
 - BATHROOM EXHAUST FAN WITH VENT TO OUTSIDE
 - ▶ SMOKE ALARM
 - ELECTRIC RISER
 - CONDUIT
 - SOLAR PANEL BOARD
 - CONTROL PANEL
 - ▬ LED 0'-2"x0'-4"x6'-0" WALKABLE FLOOR LIGHTING
 - ▬ 0'-2" LED STRIP
 - ⌞ CEILING MOUNTED FLUSH 0'-4" LIGHTING
 - MIRROR INTEGRATED LED LIGHTING
 - ⌞ WALL MOUNT LAMP, DOUBLE SIDE LIGHTING
 - ⌞ WOOD COVERED HANGING LIGHT

ELECTRIC ROOF PLAN



MAMEYES II



Cost Estimate

COST ESTIMATE					
	ITEMS	AREA	UNIT	UNIT PRICE	subtotal
A	SITE ACQUISITION (GOVERNMENT OWNED)	0 1 cuerda	SM	\$400.00	\$0.00
				SUBTOTAL A	\$0.00
B	WORK TO BE DONE ON SITE	904	SM	\$300.00	\$271,200.00
C	STRUCTURE	9,720	SF	\$90.00	\$874,800.00
D	BUILDING COMPLETIONS	9,720	SF	\$60.00	\$583,200.00
E	AIR CONDITIONING/MECHANIC	9,720	SF	\$10.00	\$97,200.00
F	PLUMBING SYSTEMS	9,720	SF	\$10.00	\$97,200.00
G	ELECTRIC WORK	9,720	SF	\$25.00	\$243,000.00
				SUBTOTAL B	\$2,069,400.00
				SUBTOTAL A & B	\$2,069,400.00
			PERCENTAGE	Subtotal A & B	
H	CONTRACT REQUIREMENTS		30.0%	\$2,069,400	\$620,820.00
				COST ESTIMATE	\$2,690,220.00

